

VOLUNTARY PARTNERSHIP AGREEMENT
BETWEEN THE EUROPEAN COMMUNITY
AND THE REPUBLIC OF GHANA
ON FOREST LAW ENFORCEMENT,
GOVERNANCE AND TRADE IN TIMBER
PRODUCTS INTO THE COMMUNITY

THE EUROPEAN COMMUNITY,

hereinafter referred to as "the Community" and

THE REPUBLIC OF GHANA,

hereinafter referred to as "Ghana"

hereinafter referred to together as the "Parties",

CONSIDERING the close working relationship between the Community and Ghana, particularly in the context of the Partnership Agreement between Members of the African, Caribbean and Pacific Group of States of the one part, and the European Community and its Member States, of the other part, signed in Cotonou (Benin) on 23 June 2000¹, hereinafter referred to as the "Cotonou Agreement";

NOTING the Communication from the Commission to the Council and the European Parliament on an EU Action Plan for Forest Law Enforcement, Governance and Trade (FLEGT) as a first step towards tackling the urgent issue of illegal logging and associated trade;

¹ OJ L 317, 15.12.2000, p 3.

HAVING REGARD to the 1992 Non-legally binding Authoritative Statement of Principles for a Global Consensus on the management, conservation and sustainable development of all types of forests, and to the recent adoption by the United Nations General Assembly of the Non-legally binding Instrument on all types of forest¹;

AWARE of the importance of principles set out in the 1992 Rio Declaration in the context of securing sustainable forest management, and, in particular, of Principle 10 concerning the importance of public awareness and participation in environmental issues and of Principle 22 concerning the vital role of indigenous people and other local communities in environmental management and development;

CONSIDERING the 1994 Forest and Wildlife Policy of Ghana which aims at conservation and sustainable development of the nation's forest and wildlife resources for maintenance of environmental quality and perpetual flow of optimum benefit to all segments of society²;

RECALLING the Ministers' Yaoundé Declaration on Forest Law Enforcement and Governance of 16 October 2003;

¹ A/RES 62/98 of 31 January 2008.

² Forest and Wildlife Policy of Ghana 1994.

HAVING REGARD to the Convention on International Trade in Endangered Species of Wild Fauna and Flora (CITES) and, in particular, the requirement that export permits issued by parties to CITES for specimens of species listed in Appendices I, II or III thereof be granted only under certain conditions, including that such specimens were not obtained in contravention of the laws of that State for the protection of fauna and flora;

RESOLVED that the Parties shall seek to minimise any adverse impacts on indigenous and local communities and poor people which may arise as a direct consequence of implementing this Agreement;

CONSIDERING the importance attached by the Parties to development objectives agreed at international level and to the Millennium Development Goals of the United Nations;

CONSIDERING the importance attached by the Parties to the principles and rules which govern the multilateral trading systems, in particular the rights and obligations in GATT 1994 and in other multilateral agreements establishing the World Trade Organisation (WTO) and to the need to apply them in a transparent and non-discriminatory manner;

HAVING REGARD to Council Regulation (EC) No 2173/2005 of 20 December 2005 on the establishment of a FLEGT licensing scheme for imports of timber into the European Community¹;

¹ OJ L 347, 30.12.2005, p. 1.

RECOGNISING that Ghana's legality assurance system is designed to ensure the legality of all timber exports;

HEREBY AGREE AS FOLLOWS:

ARTICLE 1

Objective

The objective of this Agreement, consistent with the Parties' common commitment to the sustainable management of all types of forest, is to provide a legal framework aimed at ensuring that all imports into the Community from Ghana of timber products covered by this Agreement have been legally produced and in doing so to promote trade in timber products. In addition, this Agreement provides a basis for dialogue and cooperation between the Parties to facilitate and promote the full implementation of this Agreement and enhance forest law enforcement and governance.

ARTICLE 2

Definitions

For the purposes of this Agreement, the following definitions shall apply:

- (a) "import into the Community" means the release for free circulation of timber products into the Community within the meaning of Article 79 of Regulation (EEC) No 2913/1992 of 12 October 1992 establishing the Community Customs Code¹ and which cannot be qualified as "goods of a non-commercial nature" as defined in point 6 of Article 1 of Commission Regulation (EEC) 2454/93 of 2 July 1993 laying down provisions for the implementation of Council Regulation (EEC) No 2193/92 establishing the Community Customs Code²;
- (b) "export" means the physical leaving or taking out of timber products from any part of the geographical territory of Ghana;
- (c) "timber products" means the products listed in Annex I;
- (d) "HS Code" means a six digit code as set out in the Harmonised Commodity Description and Coding System established by the International Convention on the Harmonised Commodity Description and Coding System of the World Customs Organisation;

¹ OJ L 302, 19.10.1992, p. 1.

² OJ L 253, 11.10.1993, p. 1.

- (e) "FLEGT licence" means a licence which refers to a shipment as being legally produced. A FLEGT licence may be paper-based or based on electronic means;
- (f) "licensing authority" means the authority designated by Ghana to issue and validate FLEGT licences;
- (g) "competent authorities" means the authorities designated by the EU Member States to receive, accept and verify FLEGT licences;
- (h) "shipment" means a quantity of timber products covered by a FLEGT licence that is sent by a consignor or a shipper from Ghana and is presented for release for free circulation at a customs office in the Community;
- (i) "legally-produced timber" means timber products harvested or imported and produced in accordance with the legislation as set out in Annex II.

FLEGT LICENSING SCHEME

ARTICLE 3

FLEGT Licensing Scheme

1. A "Forest Law Enforcement, Governance and Trade licensing scheme" (hereinafter "FLEGT licensing scheme") is hereby established between the Parties to this Agreement. It establishes a set of procedures and requirements aiming at verifying and attesting, by means of FLEGT licences, that timber products shipped to the Community were legally produced. In accordance with Council Regulation (EC) No 2173/2005 of 20 December 2005, the Community shall only accept such shipments from Ghana for import into the Community if they are covered by FLEGT licences.
2. The FLEGT licensing scheme shall apply to the timber products listed in Annex IA. The timber products in Annex IB may not be exported from Ghana.
3. The Parties agree to take all measures necessary to implement the FLEGT licensing scheme and in accordance with Article 12.

ARTICLE 4

Licensing Authority

1. Ghana shall designate its licensing authority. Ghana shall notify the contact details of its licensing authority to the European Commission. Both Parties shall make this information available to the public.
2. The licensing authority shall verify that timber products have been legally produced in accordance with the legislation identified in Annex II. The licensing authority will issue FLEGT licences covering shipments of legally-produced timber products for export to the Community.
3. The licensing authority shall not issue FLEGT licences for any timber products that are composed of, or include, timber products imported into Ghana from a third country in a form in which the laws of that third country forbid export, or for which there is evidence that those timber products were produced in contravention of the laws of the country where the trees were harvested.

4. The licensing authority will maintain and make publicly available its procedures for issuing FLEGT Licences. The licensing authority will also maintain records of all shipments covered by FLEGT Licences and, consistent with national legislation concerning data protection, will make these records available for the purposes of independent monitoring, while respecting the confidentiality of exporters' proprietary information.

ARTICLE 5

EU Competent Authorities

1. The European Commission shall inform Ghana of the contact details of the competent authorities of the EU Member States.
2. The competent authorities shall verify that each shipment is covered by a valid FLEGT licence prior to releasing that shipment for free circulation in the Community. The release of the shipment may be suspended and the shipment detained where there are doubts regarding the validity of the FLEGT licence. The procedures governing release for free circulation in the Community for shipments covered by a FLEGT licence are described in Annex III.

3. The competent authorities shall not permit any timber product listed in Annex IB to be released for free circulation.
4. The competent authorities shall maintain and publish annually a record of FLEGT licences received.
5. According to national legislation on data protection, the competent authorities shall grant persons or bodies designated by Ghana as independent monitors, access to the relevant documents and data.
6. The Community competent authorities will not perform the action described in paragraph 2 for shipments of timber products derived from species listed in the Appendices to the Convention on International Trade in Endangered Species of Wild Fauna and Flora (CITES) as these are covered by the provisions for verification set out in Council Regulation (EC) No 338/97 of 9 December 1996 on the protection of species of wild fauna and flora by regulating trade therein¹. The FLEGT licence system will nonetheless provide assurance of legal harvest of these products.

¹ OJ L 61, 3.3.1997, p. 1.

ARTICLE 6

FLEGT Licences

1. FLEGT licences shall be issued by the licensing authority as a means of attesting that timber products have been legally produced.
2. The FLEGT licence shall be laid out and completed in English.
3. The Parties may, by agreement, establish electronic systems for the issue, transmission and receipt of FLEGT licences.
4. The procedure for issuing FLEGT licences and the technical specifications are set out in Annex IV.

ARTICLE 7

Definition of Legally Produced Timber

For the purposes of this Agreement, a definition of "legally produced timber" is set out in Annex II. The definition sets out Ghana's national and sub-national legislation that must be complied with in order for timber products to be covered by FLEGT licences. It also sets out the documentation including criteria and indicators that shall serve as proof of compliance with such legislation.

ARTICLE 8

Verification of Legally Produced Timber

1. Ghana shall implement a system or systems to verify that timber products for shipment have been legally-produced and that only shipments verified as such are exported to the Community. The system for verification should include checks of compliance in order to provide assurance that the timber products destined for export to the Community have been legally produced and that FLEGT licences are not issued in respect of shipments of timber that have not been legally-produced, or are of unknown sources. The system shall also include procedures to ensure that timber of illegal or unknown origin does not enter the supply chain.
2. The system for verification that shipments of timber products have been legally produced is set out in Annex V.

ARTICLE 9

Consultations on validity of Licences

1. If doubt as to the validity of any licence arises, the competent authority concerned may ask the licensing authority for additional information and seek further clarification. If no answer is received by the competent authority within 21 calendar days, the competent authority shall act in accordance with national legislation in force and shall not accept the licence. If, following the provision of additional information and further investigation, it is established that information on the licence does not correspond to the shipment, the competent authority shall act in accordance with national legislation in force and shall not accept the licence.
2. Where persistent disagreements or difficulties arise in consultations concerning FLEGT licences, the matter may be referred to the Joint Monitoring and Review Mechanism.

ARTICLE 10

Independent Monitoring

1. Ghana shall engage the services of an Independent Monitor in consultation with the Community for the purposes of the functions listed in Annex VI.

2. The Independent Monitor shall be an entity that has no conflict of interest arising from any organisational or commercial relationship with the Community, or Ghana's forest sector regulatory authorities, its licensing authority, any bodies engaged by its licensing authority to verify legal timber production, or any commercial operators in its forest sector.
3. The Independent Monitor shall operate in accordance with a documented management structure and with published policies and procedures that meet internationally-accepted best practices defined by ISO 17021 (requirements for conformity assessment bodies) and ISO 19011 (guidelines for auditing procedures) or equivalent standards.
4. The Independent Monitor shall refer complaints arising from its work to the Joint Monitoring and Review Mechanism.
5. The Independent Monitor will regularly prepare full and summary reports as outlined in Annex VI.
6. The Parties will facilitate the work of the Independent Monitor including by ensuring that the Monitor has access to information as required in territories of both Parties in order to carry out its functions. However, the Parties, in accordance with their national legislation on data protection, may withhold any information which they are not permitted to communicate.

ARTICLE 11

Irregularities

The Parties shall inform each other if they suspect or have found evidence of any circumvention or irregularity in the FLEGT Licensing Scheme, including in relation to the following:

- (a) circumvention of trade, including by the re-direction of trade from Ghana to the Community via a third country, where there is reason to believe that this is done with the intention of avoiding licensing;
- (b) FLEGT licences being issued to timber products that include imports of suspect sources from third countries; or
- (c) fraud in the obtaining or use of FLEGT licences.

ARTICLE 12

Date of Operation of the FLEGT Licensing Scheme

1. Both Parties shall notify each other through the Joint Monitoring and Review Mechanism when they consider they have made the necessary preparations for the FLEGT Licensing Scheme to become fully operational.
2. The Parties, through the Joint Monitoring and Review Mechanism, shall commission an independent assessment of the scheme using the criteria set out in Annex VII. The assessment will determine that the legality assurance underpinning the FLEGT licensing scheme as described in Annex V adequately fulfils its functions and that the systems in place in the Community for receiving, verifying and accepting FLEGT licences, as set out in Article 5 and Annex III, are in place in the Community.
3. On the basis of the recommendations of the Joint Monitoring and Review Mechanism, the two Parties shall agree on a date from which the FLEGT Licensing Scheme should start full operation.
4. Both Parties shall consider the recommendation and notify each other in writing of their agreement with the recommendation.

GENERAL PROVISIONS

ARTICLE 13

Application of FLEGT Licensing Scheme to Timber Products Not Exported to the Community

1. Ghana shall endeavour to verify the legality of timber sold on domestic markets and of imported timber, using, where possible, the systems developed for the implementation of this Agreement.
2. In support of such endeavours, the Community shall encourage, where appropriate and in dialogue with interested parties, the use of the systems developed for the implementation of this Agreement.

ARTICLE 14

Schedule for implementation of the Agreement

1. The Parties agree to the implementation schedule set out in Annex VIII.

2. The Parties, working through the Joint Monitoring and Review Mechanism, will evaluate progress made in implementation with reference to the schedule set out in Annex VIII.

ARTICLE 15

Supporting Measures

1. The Parties agree that in order to address the root causes and drivers of illegal logging, supplemental measures are required to strengthen sector governance and the legal framework. Particularly with regard to tackling the challenges of growing domestic demand and the need to retool industry to remain competitive, Ghana shall endeavor to undertake measures as outlined in Annexes IX and II.

2. The Parties have identified the areas set out in Annex IX as those in which there is a need for technical and financial resources in order to implement this Agreement.

3. The provision of such resources shall be subject to the procedures governing the Community assistance as foreseen in the Cotonou Agreement and in those governing the bilateral EU Member States' assistance to Ghana.

4. The Parties shall ensure that activities implemented under this Agreement are coordinated with existing and future relevant development programmes and initiatives.

ARTICLE 16

Stakeholder Involvement in the Implementation of the Agreement

1. Ghana, where feasible, shall endeavour to encourage stakeholder consultation in the implementation of this Agreement.
2. Ghana, in line with its principle of participatory management and protection of forest and wildlife resources, will promote appropriate strategies, modalities and programmes in consultation with relevant stakeholders in the implementation of this Agreement.
3. The Community will hold regular consultations with stakeholders on the implementation of this Agreement, taking into account its obligations under the 1998 Aarhus Convention on access to information, public participation and access to justice in environmental matters.

ARTICLE 17

Social Safeguards

1. In order to minimise possible adverse impacts, the Parties agree to develop a better understanding of the livelihoods of potentially affected indigenous and local communities as well as the timber industry, including those engaged in illegal logging.

2. The Parties will monitor the impacts of this Agreement on those communities and other actors identified in paragraph 1, while taking reasonable steps to mitigate any adverse impacts. The Parties may agree on additional measures to address adverse impacts.

ARTICLE 18

Market incentives

Taking into account its international obligations, the Community shall strive to promote favourable access to its market for the timber products covered by this Agreement. Such efforts will include:

- (a) the encouragement of public and private procurement policies that recognise efforts to ensure a supply of legally harvested forest produce; and
- (b) the promotion of FLEGT-licensed products to the European timber market.

ARTICLE 19

Joint Monitoring and Review Mechanism

1. The Parties shall establish a joint mechanism to facilitate the monitoring and review of this Agreement (referred to in this Agreement as the "Joint Monitoring and Review Mechanism" (JMRRM)). The JMRRM shall be constituted by periodic missions jointly undertaken by the Parties.
2. Each Party shall nominate its representatives. The composition of the JMRRM shall respect the principles of equality and parity.
3. The JMRRM shall consider any matter relating to effective implementation of the Agreement through dialogue and exchange of information between the Parties. In particular the JMRRM shall:
 - (a) recommend the date upon which the FLEGT licensing scheme should be fully operational;
 - (b) review reports issued by the Independent Monitor and any complaint about the operation of the FLEGT licensing scheme in the territory of either of the Parties;
 - (c) monitor, when applicable, actions taken to address the problems identified by the Independent Monitor;

- (d) assess the social, economic and environmental impacts of this Agreement, in accordance with relevant good practice and criteria to be agreed by the Parties and address any issues raised as a result of the assessment;
- (e) address matters of concern raised by either of the Parties and attempt to resolve any conflict that may arise, to the extent possible;
- (f) provide appropriate recommendations on capacity-building needs for the successful implementation of the Agreement;
- (g) review developments in public procurement policies;
- (h) monitor and report on the market situation at regular intervals, commissioning studies as necessary and recommending actions to be taken arising from market intelligence reports;
- (i) review and agree on annual reports on the progress of implementation, and
- (j) regularly issue public summary reports based on the findings of the Independent Monitor as explained in Annex VI.

4. The JMRM shall:
 - (a) meet at least once a year on a date agreed by the Parties;
 - (b) together develop the agenda and terms of reference for joint actions;
 - (c) establish its own rules of procedures;
 - (d) preside over its meetings either in turns by representatives of each Party or by a co-chair arrangement, and
 - (e) if necessary, establish working groups or other subsidiary bodies for areas of work requiring specific expertise.

ARTICLE 20

Reporting and Public Disclosure

1. The Parties will ensure that the workings of the JMRM are as transparent as possible and that reports and *aide memoires* arising out of missions are jointly prepared and distributed to the Parties and made public.

2. The JMRM shall conduct regular joint missions to review the effectiveness of the Agreement as well as its impact based on the information available. It shall record the efforts Ghana has made to be transparent by, *inter alia*, making publicly available information about harvest rights, areas designated for harvesting, harvesting schedules, timber rights fees, and harvest related payments, and information on social responsibility agreements and crop damage compensation awards.

3. On the basis of information from the Parties, the JMRM shall make public a yearly report. The report should include, *inter alia*, details on:

- (a) the quantities of timber products exported to the Community under the FLEGT licensing scheme, according to the relevant HS headings;
- (b) the number of FLEGT licences issued by Ghana;
- (c) progress in the achievement of the objectives and the time-bound actions in the Agreement and matters relating to the implementation of the Agreement;
- (d) actions to prevent illegally-produced timber products being exported to non-Community markets or traded on the domestic market;
- (e) actions taken to prevent imports of illegally-produced timber products and maintain the integrity of the FLEGT licensing Scheme;

- (f) quantities of timber products imported to the Community under the FLEGT licensing scheme, according to the relevant HS headings and EU Member State in which importation into the Community took place;
- (g) number of FLEGT licences received by the Community;
- (h) number of cases and quantities of timber products involved where Article 9(1) has been applied.

ARTICLE 21

Communication on implementation of the Agreement

1. The representatives of the Parties responsible for official communications concerning implementation of this Agreement are:

For Ghana:

Minister of Lands, Forestry and Mines

For the Community:

Head of Delegation, EC in Ghana

2. The Parties shall communicate to one another in a timely manner the information necessary for implementing this Agreement.

ARTICLE 22

Confidential Information

1. Each Party agrees to maintain, to the extent required under its laws, the confidentiality of confidential information exchanged under this Agreement. Neither Party shall disclose to the public, nor permit its authorities to disclose, information exchanged under this Agreement that constitutes trade secrets or confidential commercial information.
2. Subject to paragraph 1, the following information shall not be considered confidential:
 - (a) the number and type of FLEGT licences issued by Ghana and received by the Community and the volume of timber products exported from Ghana and received by the Community under such licences;
 - (b) the name and address of the licence holder and of the importer.

ARTICLE 23

Territorial application

This Agreement shall apply, on the one hand, to the territory in which the Treaty establishing the European Community is applied under the conditions laid down in that Treaty and, on the other hand, to the territory of Ghana.

ARTICLE 24

Settlement of disputes

1. Parties shall seek to resolve any dispute concerning the application or interpretation of this Agreement by means of prompt consultations.
2. If a dispute has not been settled by means of consultations within two months from the date of the initial request for consultations, either Party may refer the dispute to the JMRRM which shall endeavour to settle the dispute. The JMRRM shall be provided with all relevant information for an in-depth examination of the situation with a view to finding an acceptable solution. To this end, the JMRRM shall be required to examine all possibilities for maintaining the good functioning of this Agreement.
3. In the event that the JMRRM is unable to settle the dispute within two months, the Parties may jointly seek the good offices of, or request mediation by, a third party.
4. In the event of it not being possible to settle the dispute in accordance with paragraph 3, either Party may notify the other of the appointment of an arbitrator; the other party must then appoint a second arbitrator within 30 calendar days of the appointment of the first arbitrator. The Parties jointly shall appoint a third arbitrator within two months of the appointment of the second arbitrator.

5. The arbitrator's decisions shall be taken by majority vote within six months of the third arbitrator being appointed.
6. The award shall be binding on the Parties and it shall be without appeal.
7. The JMRM shall establish the working procedures for arbitration.

ARTICLE 25

Suspension

1. Either Party may suspend the application of this Agreement. The decision on suspension and the reasons for that decision shall be notified to the other Party in writing.
2. The conditions of this Agreement will cease to apply 30 calendar days after such notice is given.
3. Application of this Agreement shall resume 30 calendar days after the Party that has suspended its application informs the other Party that the reasons for the suspension no longer apply.

ARTICLE 26

Amendments

1. Either Party wishing to amend this Agreement shall put the proposal forward at least three months before the next meeting of the JMRM. The JMRM will discuss the proposal and, if consensus is achieved, shall make a recommendation. Each Party shall consider the recommendation and, subject to its agreement, it shall approve it in accordance with its own procedures.
2. Any amendment so approved by both Parties shall enter into force on the first day of the month following the date on which the Parties notify each other of the completion of the procedures necessary for this purpose.
3. The JMRM may adopt amendments to the Annexes to this Agreement.
4. Notification of any amendment shall be sent to the joint depositaries for this Agreement.

ARTICLE 27

Duration and Extension

This Agreement shall remain in force for a period of 10 years and shall be extended for consecutive periods of five years, unless a Party renounces the extension by notifying to the other Party in writing at least one year before the expiration of the Agreement.

ARTICLE 28

Termination

Notwithstanding Article 27, either Party may terminate this Agreement by notifying the other Party. This Agreement shall cease to apply 12 months after the date of such notification.

ARTICLE 29

Annexes

The Annexes to this Agreement shall form an integral part thereto.

ARTICLE 30

Authentic texts

This Agreement shall be drawn up in duplicate in the Bulgarian, Czech, Danish, Dutch, English, Estonian, Finnish, French, German, Greek, Hungarian, Italian, Latvian, Lithuanian, Maltese, Polish, Portuguese, Romanian, Slovak, Slovenian, Spanish, and Swedish languages, each of these texts being authentic. In case of divergence of interpretation, the English text shall prevail over the other language texts.

ARTICLE 31

Entry into force

1. This Agreement shall enter into force on the first day of the month following the date on which the Parties notify each other in writing of the completion of the procedures necessary for this purpose.
2. Notification shall be sent to the Secretary-General of the Council of the European Union and to the Ghana Ministry of Foreign Affairs, who shall be the joint depositaries for the Agreement.

Съставено в Брюксел на двадесети ноември две хиляди и девета година.

Hecho en Bruselas, el veinte de noviembre de dos mil nueve.

V Bruselu dne dvacátého listopadu dva tisíce devět.

Udfærdiget i Bruxelles den tyvende november to tusind og ni.

Geschehen zu Brüssel am zwanzigsten November zweitausendneun.

Kahe tuhande üheksanda aasta novembrikuu kahekümnendal päeval Brüsselis.

Έγινε στις Βρυξέλλες, στις είκοσι Νοεμβρίου δύο χιλιάδες εννιά.

Done at Brussels on the twentieth day of November in the year two thousand and nine.

Fait à Bruxelles, le vingt novembre deux mille neuf.

Fatto a Bruxelles, addì venti novembre duemilanove.

Briselē, divi tūkstoši devītā gada divdesmitajā novembrī.

Priimta du tūkstančiai devintų metų lapkričio dvidešimtą dieną Briuselyje.

Kelt Brüsszelben, a kétézer-kilencedik év november huszadik napján.

Magħmul fi Brussell, fl-għoxrin jum ta' Novembru tas-sena elfejn u disgħa.

Gedaan te Brussel, de twintigste november tweeduizend negen.

Sporządzono w Brukseli dnia dwudziestego listopada roku dwa tysiące dziewiątego.

Feito em Bruxelas, em vinte de Novembro de dois mil e nove.

Înceiat la Bruxelles, la douăzeci noiembrie două mii nouă:

V Bruseli dňa dvadsiateho novembra dvetisícdeväť.

V Bruslju, dne dvajsetega novembra leta dva tisoč devet.

Tehty Brysselissä kahdentenäkymmenentenä päivänä marraskuuta vuonna kaksituhattayhdeksän.

Som skedde i Bryssel den tjugonde november tjugohundraio.

За Европейската Общност
Por la Comunidad Europea
Za Evropské společenství
For Det Europæiske Fællesskab
Für die Europäische Gemeinschaft
Euroopa Ühenduse nimel
Για την Ευρωπαϊκή Κοινότητα
For the European Community
Pour la Communauté européenne
Per la Comunità europea
Eiropas Kopienas vārdā
Europos bendrijos vardu
Az Európai Közösség részéről
Għall-Komunità Ewropea
Voor de Europese Gemeenschap
W imieniu Wspólnoty Europejskiej
Pela Comunidade Europeia
Pentru Comunitatea Europeană
Za Európske spoločenstvo
Za Evropsko skupnost
Euroopan yhteisön puolesta
För Europeiska gemenskapen



За Република Гана
Por la República de Ghana
Za Ghanskou republiku
For Republikken Ghana
Für die Republik Ghana
Ghana Vabariigi nimel
Για τη Δημοκρατία της Γκάνας
For the Republic of Ghana
Pour la République du Ghana
Per la Repubblica del Ghana
Ganas Republikas vārdā
Ganos Respublikos vardu
A Ghánai Köztársaság részéről
Għar-Repubblika tal-Ghana
Voor de Republiek Ghana
W imieniu Republiki Ghany
Pela República do Ghana
Pentru Republica Ghana
Za Ghanskú republiku
Za Republiko Gano
Ghanan tasavallan puolesta
På Republiken Ghanas vägnar



LIST OF ANNEXES

Annex I	IA Products Covered by the FLEGT Licensing Scheme. IB Products not covered by the FLEGT Licensing Scheme.
Annex II	Legislation to Be Taken Into Account in Determining the Legality of a Shipment of Timber, documentation to be used as proof of compliance, and forest policy and legislative reform aspiration.
Annex III	Community Importation procedures including verification of Licences.
Annex IV	FLEGT Licence Specifications.
Annex V	Legality Assurance Scheme, including the procedure for issuing FLEGT Licences (wood tracking system, verification, licensing and independent monitoring).
Annex VI	Terms of Reference for Independent Monitoring.
Annex VII	Criteria for assessment of the Legality Assurance Scheme.
Annex VIII	Schedule for Implementation of the Agreement.
Annex IX	Supporting Measures for VPA Implementation.

ANNEX IATHE HARMONISED COMMODITY CODES FOR TIMBER AND WOOD PRODUCTS
COVERED UNDER THE VPA

HS CODES	DESCRIPTION
440349	Wood in rough, whether or not striped of bark or sapwood or roughly squared (Teak in the rough).
440610 440690	Railway Sleepers and cross-ties of wood.
440710 440725 440726 440727 440728 440729 440799	Wood sawn or chipped lengthwise, sliced or peeled, whether or not planed, sanded or finger-jointed.
440810 440831 440839 440890	Veneer sheets and sheets of plywood (whether or not sliced).
440921 440929	Wood (including strips and friezes for parquet flooring, not assembled) continuously shaped (tongued, grooved, rebated, chamfered, v-jointed, beaded. Moulded, rounded or the like) along any of its edges, ends or faces, whether or not planed, sanded or end-jointed.
441210 441231 441232 441239 441294 441299	Plywood, veneered panels and similar laminated wood.

441810 441820 441850 441860 441871 441872 441879 441900	Builders' joinery and carpentry of wood, including cellular wood, panels, assembled flooring panels, shingles and shakes.
442010	Wood marquetry and inlaid wood; caskets and cases for jewellery or cutlery and similar articles of wood; statuettes and other ornaments of wood; wooden articles of furniture not falling within chapter 94.
940151 940159	Seats other than those of heading 94.02.

ANNEX IB

THE HARMONISED COMMODITY CODES FOR TIMBER NOT PERMITTED FOR
EXPORT

HS CODES	DESCRIPTION
440349	Wood in rough, whether or not striped of bark or sapwood or roughly squared (all logs with the exception of teak are not permitted for export).

LEGALITY DEFINITION FOR ISSUANCE OF FLEGT EXPORT LICENCE AND
LEGAL REFORM PROCESS

1. PREAMBLE

As a requirement of the Voluntary Partnership Agreement, Ghana has, through stakeholder consultation, developed a legal standard to underpin the implementation of this agreement. The legal standard is linked to the Legality Assurance System through the legality matrix. This document presents the legal definition, the legality matrix, a summary of relevant laws and regulations governing the forest sector, as well as describing the processes through which Ghana will reform and consolidate laws in the forestry sector.

2. ANNOTATED LEGAL DEFINITION

A product containing wood sourced from Ghana can be licensed for sale within Ghana or for export from Ghana:

(a) in cases where the source and ownership is a felling permit:

(i) timber originated from prescribed sources¹ and the individual, group and owners concerned gave their consent to the logging of the resource²;

¹ Act 547 Section 4, and LI 1649 Regulations 1 and 2.

² LI 1649 Regulations 2 - 8.

- (ii) the logger, at the time of felling, held a valid Timber Utilisation Contract (TUC), issued by the Minister for Lands Forests and Mines ratified by Parliament following the prescribed competitive process¹;
 - (iii) the logger at the time of felling, held a valid Salvaging Permit (SP) issued by the Forestry Commission²; or
 - (iv) the logger complied with forest operation procedures and standards prescribed by statute³;
 - (v) The logger at the time of felling has been granted replacement⁴ for timber rights.
- (b) In cases where the source and ownership is a Certificate of Purchase-COP:
- (i) The COP was issued pursuant to a court order confiscating the timber⁵;
 - (ii) the wood was abandoned and sold by the Forestry Commission in accordance with statutory procedures⁶;

¹ Act 547 Section 1, 7, 8, 9 and LI 1721 Regulations 9 - 13.

² LI 1649 S 38.

³ Act 547 Section 18(d) and LI 1649 Regulations 16 - 20.

⁴ Act 547 Section 15(1) c, d, e.

⁵ Section 17(3), Act 547 and Section 37, LI 1649.

⁶ S37 of LI 1649.

- (c) the wood was at all times transported in accordance with standards prescribed by statute¹;
- (d) the wood was processed in accordance with standards prescribed by statute²; and
- (e) all vendors/exporters have valid licence or permits to market timber³;
- (f) at the time of sale or export no accrued fees, rents or taxes, prescribed by statute were owing to the State⁴; and
- (g) at the time of sale or export, the logger had complied fully with obligations under Social Responsibility Agreements⁵.

3. LEGALITY MATRIX

In determining whether wood sourced from Ghana meets the standard set out in the definition of "Legal Timber" as stated above, the principles and criteria as set out in table 1 below shall apply.

¹ LI 1649 Regulation 18.

² Factory Offices and Shops Act (Act 328) and Labour Act (Act 651).
³ Act 571 Section 2(i) and (ii).

⁴ Act 547 S8 (e) and (f), and LI 1649 S 21, 27.

⁵ Section 14 LI 1721.

Table 1: Principles and Criteria for Legal Standard

PRINCIPLE 1	Source of Timber: Timber originated from prescribed sources and concerned individual, group and owners gave their written consent to the land being subjected to the grant of timber rights.
CRITERION 1.1	<p>For Timber Utilisation Contracts (TUC) in on-reserves, forest management plan preparation covers strategic plan;</p> <p>Delineation of TUCs;</p> <p>Conduction of an inventory before harvesting (on-reserve, off-reserve and plantation);</p> <p>Written consent of concerned individual, group or owners.</p>
Guidance notes on relevant Legislation/Regulations	<p>LI. 1649 PART1: Procedure for grant of timber rights; Subpart1-identification of lands suitable for the grant of timber rights;</p> <p>MOP Section A - Strategic planning (forest reserves);</p> <p>MOP Section B - operational planning (forest reserves); Instruction sheet B2 operational planning methodology (on-reserve delineation);</p> <p>MoP Section C – Timber Production in Forest Reserve;</p> <p>MOP Section F- Controlled timber production off-reserve 2.1 (ii) Identification of TUC areas and 3.7 (C) (off-reserve delineation);</p> <p>F3.2 Consultation process (written consent);</p> <p>Manual of Procedures (MoP)¹ – Sustainable timber production on-reserve (section C); Stock survey and yield allocation (section D) and Controlled timber production off-reserve (section F).</p>

¹ Legal status of MoPs: MoPs are output of requirements in Section 18 of the Timber Resource Management Act 547 and accompanying Timber Resource Management Regulation LI 1649 Section 14 repealed by Timber Resource Management (Amendment) Regulation LI 1721, Section 14 which provides for the terms and conditions of TUC.

PRINCIPLE 1	Source of Timber: Timber originated from prescribed sources and concerned ,individual, group and owners gave their written consent to the land being subjected to the grant of timber rights.
CRITERION 1.2	Land owner, individual or group written consent.
Guidance notes for relevant Legislation/Regulations	Act 547: Timber Resources Management Act section 4, subsection 2 (d); LI1649: Part 1 procedure for grant of Timber Rights, subpart 1: field inspection 2 (d); Subpart II Procedure in relation to lands other than public land and existing forest reserves; MoP Section F (Controlled Timber Production Off-Reserve) - F3.2 – consultation process; MoP Section F, F5.0: Finalisation (endorsements).

PRINCIPLE 2	<u>Timber Rights Allocation</u> The logger held a TUC issued by the Minister and ratified by Parliament following the specified competitive process or Logger held a Salvage Permit issued by the Forestry Commission.
CRITERION 2.1	<u>Natural Forest and Plantation TUCs;</u> Qualification of loggers for grant of TUC by TREC.
Guidance notes for relevant Legislation/other references	LI 1721:Part II: Procedure for Competitive bidding for grant of timber right Q; LI 1649: Terms and conditions of TUC (section 14 Act 547: Ratification by parliament (Section 9).

PRINCIPLE 2	<u>Timber Rights Allocation</u> The logger held a TUC issued by the Minister and ratified by Parliament following the specified competitive process or Logger held a Salvage Permit issued by the Forestry Commission.
CRITERION 2.2	<u>Salvage permit</u> Issuance of Salvage Permit.
Guidance for relevant Legislation/Regulations	Regulation on procedure for salvage timber (Act 547 section 18g); salvage of timber products LI1649 Section 38.

¹ The Forestry Commission issues a permit subjected to such terms and conditions as shall be specified therein for the salvage of trees from an area of land undergoing development such as road construction, expansion of human settlement or cultivation of farms.

PRINCIPLE 2	<u>Timber Rights Allocation</u> The logger held a TUC issued by the Minister and ratified by Parliament following the specified competitive process or Logger held a Salvage Permit issued by the Forestry Commission.
CRITERION 2.3	<u>Confiscated Timber</u> Permit for duly auctioned confiscated timber issued.
Guidance for relevant Legislation/Regulations	Offences - Act 547 Section 17 (3); and Salvage and disposal of abandoned timber product (LI 1649 Section 37).

PRINCIPLE 3	<u>Timber Harvesting Operations</u> The logger complied with forest operation procedures and standards specified by statute.
CRITERION 3.1	Stock surveys (including pre-felling inspections for off-reserve areas) were conducted in accordance with the logging manual. Harvesting plan.
Guidance notes for relevant Legislation/Regulations	Logging Manual (Section 10 of Act 547). Logging Manual means a set of rules intended to guide the activities of persons who harvest timber in the forest as interpreted in Act 547 (Section 20). MoP Section D (Stock Survey and Yield section).

PRINCIPLE 3	<u>Timber Harvesting Operations</u> The logger complied with forest operation procedures and standards specified by statute (LI 1649).
CRITERION 3.2	Logging was carried out in accordance with harvesting requirement in areas designated for timber production.
Guidance notes for relevant Legislation/Regulations	Procedure relating to timber operations (i.e. Harvesting plan) - LI 1649 Section 17; MoP Section E - Preparation of timber harvesting schedules for forest reserve; MoP Section F - Controlled Timber Production Off-reserve (Instruction Sheet F4.3 – The annual logging plan); Other sources of timber production (e.g. Plantation, underwater harvesting) as specified by the contract terms, Logging Manual Section 3 (timber harvesting standards and specification).

PRINCIPLE 3	<u>Timber Harvesting Operations</u> The logger complied with forest operation procedures and standards specified by statute.
CRITERION 3.3	Logs were accurately measured and recorded.
Guidance notes for relevant Legislation/Regulations	MoP section C, Records, Reporting and Auditing procedures C5.0. MoP Section F, Records and Reporting procedures F5.0.

PRINCIPLE 3	<u>Timber Harvesting Operations</u> The logger complied with forest operation procedures and standards specified by statute.
CRITERION 3.4	Timber harvested corresponded to the species and volumes or numbers authorised in the TUC or Salvage permit.
Guidance for relevant Legislation/Regulations	LI 1649 Section 23 – Measurement of timber; Marking Logging Manual appendix 5: Logging Control Forms (TIF and LIF).
PRINCIPLE 3	<u>Timber Harvesting Operations</u> The logger complied with forest operation procedures and standards specified by statute.
CRITERION 3.5	Stumps and logs were marked and numbered in accordance with the logging manual.
Guidance for relevant Legislation/Regulations	LI 1649 Section 20; Marking and numbering of trees, logs and timber products; Logging Manual Section 3: Timber harvesting standard and specifications (log markings).

PRINCIPLE 3	<u>Timber Harvesting Operations</u> The logger complied with forest operation procedures and standards specified by statute.
CRITERION 3.6	The logger executed and complied with the relevant Social Responsibility Agreement.
Guidance notes on relevant Legislation/Regulations	Section 14 of LI 1721; Logging Manual Sections 3 - code of conduct (on-reserve) that recognises the rights of other users and show respect for cultural norms such as taboo days etc; and code of conduct - (off-reserve) that recognises the rights of other users and show respect for farming operation etc. Section 4.1 - Monitoring of timber harvesting operation (Social responsibility assessment); 4.2-Penalties.

PRINCIPLE 3	<u>Timber Harvesting Operations</u> The logger complied with forest operation procedures and standards specified by statute.
CRITERION 3.7	Compensation was paid to affected farmers in respect of crop damage if any.
Guidance for relevant Legislation Regulations	Logging Manual Section 4.2 (Penalties).

PRINCIPLE 4.	<u>Transportation</u> Timber was at all times transported in accordance with standards prescribed by statute.
CRITERION 4.1	Timber was transported with official documentation detailing its origin and corresponding with physical identification of the timber.
Guidance for relevant Legislation Regulations	Logging Manual Section 3: Timber harvesting standards and logging control appendix 5.

PRINCIPLE 4	<u>Transportation</u> Timber was at all times transported in accordance with standards prescribed by statute.
CRITERION 4.2	Timber was transported within the time periods permitted by law.
Guidance for relevant Legislation Regulations	Procedure relating to timber operations (Approved periods of timber operations and transport of forest produce): LI1649 Section 18.

PRINCIPLE 5	<u>Processing</u>
CRITERION 5.1	Timber processing facilities have valid licences and registration with FC and complied with all legal requirements.
Guidance on relevant Legislation Regulations	Act 571 Section 2.

PRINCIPLE 5	<u>Processing</u>
CRITERION 5.2	Industrial relation practices conform to legal standards.
Guidance for relevant Legislation Regulations	Occupational Health, Safety and Environment: Act 651 Labour Act Section 118-124; LI 1833: Health and employment (Section 18-20) and Office and Factories Act.

PRINCIPLE 6	<u>Trade</u> All vendors/exporters have valid licence or permits to market timber.
CRITERION 6.1	Exporters have acquired FC permit.
VERIFICATION	Valid export licence.
Guidance for relevant Legislation Regulations	Act 571 Section 2 (i) vetting and the registration of contracts to market timber products and such forest and wildlife products as the commission may determine.

PRINCIPLE 6	<u>Trade</u> All vendors/exporters have valid licence or permits to market timber.
CRITERION 6.2	Domestic Vendors have FC registration.
Guidance on relevant Legislation Regulations	Act 571 Section 2 (ii) the establishment of procedures to track the movement of timber, wood and wildlife products. TVD <u>audit</u> reports on supply of wood products to the domestic market.

PRINCIPLE 7	<u>Fiscal Obligations</u> Neither the logger nor the Vendor was at the time of sale or export in default of fees, rents or taxes, prescribed by statute.
CRITERION 7.1	Logger was not in default of stumpage fees or any other fees payable by loggers in Ghana.
Guidance notes on relevant Legislation/Regulations	Procedure relating to timber operation (payment of stumpage) LI 1649 Section 25. TVD <u>audit</u> reports on financial flows reconciliation.

PRINCIPLE 7	<u>Fiscal Obligations</u> Neither the logger nor the Vendor was at the time of sale or export in default of fees, rents or taxes, prescribed by statute.
CRITERION 7.2	Logger was not in default of ground rents.
Guidance on relevant Legislation Regulations	Timber stumpage fees and contract area rent- LI1649 PART V Section 27.

PRINCIPLE 7	<u>Fiscal Obligations</u> Neither the logger nor the Vendor was at the time of sale or export in default of fees, rents or taxes, prescribed by statute.
CRITERION 7.3	Exporter was not in default of export levies.
Guidance on relevant Legislation /Regulations	Export levies: Trees and timber Amendment Act 493 Section 4.

PRINCIPLE 7	<u>Fiscal Obligations</u> Neither the logger nor the Vendor was at the time of sale or export in default of fees, rents or taxes, prescribed by statute.
CRITERION 7.4	Neither Logger nor exporter was in default of corporate income tax.
Guidance on relevant Legislation /Regulations	Imposition of Income Tax (Income from a Business): Act 592 Section 7.

4. LAWS AND REGULATIONS IN FORCE IN GHANA

The definition of "Legal Timber" represents a subset of the laws contained within the legal framework for timber harvesting, processing and export in Ghana. Through multi-stakeholder consultation, it has been agreed that verification of compliance with these laws will be required in order to issue a FLEGT licence. The laws and regulations in force in Ghana, from which this definition was extracted, include:

CONSTITUTIONAL PROVISIONS, 1992

1. Article 258 Establishes a Lands Commission and prescribes the functions of the Commission.

2. Article 267(1) Vests stool lands in the appropriate stools in trust for their subjects in accordance with customary law and usage.
3. Article 266 Imposes restrictions on the rights and interest in land that could be granted to a non-citizen of Ghana.
4. Article 267(2) Establish the Office of Administrator of Stool Lands and prescribes its functions.
5. Article 267(6) Provides for the disbursement formula for stool land revenue.
6. Article 268 Requirement of Parliamentary ratification of agreements relation to the grant of a right or concession for the exploitation of any natural resources.
7. Article 269 Establish natural resources commissions [Forestry Commission] which "shall be responsible for the regulation and management of the utilisation of the natural resources concerned and the co-ordination of policies in relation to them".
8. Article 295 Provides for the definition of Stool lands.

PRIMARY LEGISLATION

9. Forest Protection Decree, 1974 (N.R.C.D. 234) – This Act defined forest offences and prescribed sanctions and or penalties for such offences.
10. Forest Protection (Amendment) Law, 1986 (P.N.D.C.L. 142) – This law reviewed upwards the penalties/fines for forest offences.
11. FORESTS Ordinance (Cap 157) – This Act provided guidelines for constitution of forest reserves and the protection of forests and other related matters.
12. Trees and Timber Decree 1974 (N.R.C.D. 273) – This law prescribed guidelines for participation in the logging/ timber industry and provided for the payment of fees as well as sanctions for non- compliance with the guidelines for participation and also export of unprocessed timber.
13. Trees and Timber (Amendment) Act 1994 (Act 493) – This Act reviewed the fees and fines upwards and also introduced export levy for air-dried lumber and logs.
14. Timber Resources Management Act 1997 (Act 547) – This repealed the Concessions Act, 1962 (Act 124) and provided for the grant of timber rights in a manner that secures the sustainable management and utilisation of timber resources.

15. Forestry Commission Act, 1999 (Act, 571) – This Act repealed ACT 453 and re-establish the Forestry Commission as a semi-autonomous corporate body and also brought under the Commission, the forestry sector agencies implementing the functions of protection, development, management and regulation of forest and wildlife resources.
16. Forest Plantation Development Fund Act, 2000 (Act 583) – This Act consolidate to it the Forest Improvement Fund and provide for the establishment of a Fund to provide financial assistance and the management of such funds for the development of private commercial forest plantations in the country.
17. The Forest Protection (Amendment) Act 2002 (Act 624) – This Act repealed the Forest Protection (Amendment) Law, 1986 (PNDCL. 142), reviewed forest offences fines upwards and introduced joint liability in the commitment and prosecution of forest offences.
18. The Forest Plantation Development Fund (Amendment) Act 2002 (Act 623) – This Act amended ACT 583 to enable plantation growers, both in the public and private sectors to participate in forest plantation development.
19. Timber Resources Management (Amendment) Act 2002 (Act 617) – This Act amended ACT 547 to exclude from its application, land with private forest plantation, to provide for maximum duration, and maximum limit area for timber rights and to provide for incentives and benefits for investors in the forestry and wildlife sector.

20. Factories, Offices and Shops Act, 1970 (Act 238) – This Act provides for the registration of factories, welfare and safety of employees in factories and other places of work.
21. Social Security Law, 1991 (PNDCL. 247) – This Law establishes a trust fund to provide social protection to the working population.
22. Internal Revenue Act, 2000 (Act 592) – Provides for taxation of individuals and other entities and for related matters.
23. Value Added Tax Act, 1998 (Act 546) – Provides for the imposition of a VAT on specified transactions and activities.
24. Economic Plants Protection Decree, 1979 (AFRCD. 47) – Prohibits the grant of timber felling rights in cocoa farms.

SUBSIDIARY LEGISLATION

25. LI 1649 timber Resources Management Regulations, 1988 – This Regulation provided guidelines for the allocation and management of timber resources.
26. LI 1721 – timber Resources Management (Amendment) Regulations, 2003. This Regulations established basis for competitive bidding in timber resource allocation.

5. FOREST POLICY AND LEGISLATIVE REFORM ASPIRATION

Ghana recognises that the provisions in the existing law which provides grounds for the forgoing legality definition framework needs to undergo significant reforms to be able to address existing inadequacies as well respond to emerging issues in the sector that bothers on the principles of good governance. Ghana wishes therefore to indicate its intension to carry out legal and policy reforms in the spirit of good forest governance. It is expected that such legal reforms could be completed in the next five years.

Areas that require policy and legal reforms include:

- Initiation of process to amend the Savings and Transitional provisions of Act 547 in respect of conversion of extant leases/concession to Timber Utilisation Contracts and the related matter of Timber Rights Fee payment;
- Plantation development and harvesting;
- Timber processing and standard setting for the timber industry;
- Import of raw material (wood);

- Domestic market development:
 - (a) (small to medium size enterprises);
 - (b) resource allocation;
 - (c) Standardisation of wood components in building and constructional industry;
 - (d) Introduction of public procurement policies.

- Institutional arrangements and Forest control processes:
 - (a) Timber Validation Entity;
 - (b) Governing council;
 - (c) Independent Monitoring;
 - (d) Bar codes.

- Submerged Timber Resource allocation (Volta lake);

- Workers health and safety requirements for forest operation;

- A clear statement of resource governance objectives – public interest in biodiversity sustenance, rural livelihoods, sustainable industrialisation and cultural development Identification and correction of inconsistencies in existing forest laws that relate to definition of legal timber (e.g. issuance of salvage permits in respects of lands under Timber Utilisation Contract;
- affirmation of local forest tenure and of different stakeholder rights, particularly farmers in different types of forests and clarification of the respective scope of local (including customary) and national institutions in forest management to:
 - (a) sustain forests;
 - (b) develop and exploit forests (both timber and non-timber).
- Investment Regulation:
 - (a) Incentives, regulation, fiscal and benefits sharing for Non-Timber Forest Products (including tourism and environmental services);
 - (b) Incentives, regulation, fiscal and benefits sharing arrangements for extractive investments;

- (c) Incentives, regulation, fiscal and benefits sharing arrangements for reforestation;
- (d) Incentives, regulation, fiscal and benefits sharing arrangements for plantations; and
- (e) Incentives, regulation, fiscal and benefits sharing arrangements for processing.

IMPLEMENTATION

To move from the existing towards the future legal standards, the Ghana anticipates a two tier reform approach to deal with obsolete, disjointed and inconsistent laws and also introduce new laws to give effect to evolving policies:

- Changes to areas that do not require extensive legal reform process will be realised through subsidiary legislation one year of agreeing a Voluntary Partnership Agreement;
- Changes that will require extensive consultations, involvement of experts and considerable political reflections, pertaining to e.g. good governance issues, stakeholder participation, benefit sharing etc. is expected to take about 3-5 years.

CONDITIONS GOVERNING THE RELEASE FOR FREE CIRCULATION INTO THE
COMMUNITY OF TIMBER PRODUCTS EXPORTED FROM A PARTNER COUNTRY
AND COVERED BY A FLEGT LICENCE

Article 1

1. The FLEGT licence, hereinafter referred to as "licence", shall be lodged with the competent authority of the Member State in which the shipment covered by that licence is declared for release for free circulation.
2. The competent authority referred to in paragraph 1 shall, in accordance with the applicable national procedures, inform the customs authorities that a licence has been accepted.
3. A licence shall be considered as void if the date on which it is lodged is later than the date of expiry indicated in the licence.
4. A licence lodged before the arrival of the shipment that it covers may be accepted if the licence meets all the requirements set out in Annex IV to this Agreement and no further verification in accordance with Article 3(1) is deemed necessary.

5. Where further information of the licence or of the shipment in accordance with Articles 3 and 4 is required, the licence shall be accepted only after the submission of information on the validity of the licence.
6. Costs incurred while the verification is completed shall be at the expense of the importer, except where national legislation of Member States concerned determines otherwise.

Article 2

1. Any erasures in or alterations to a licence shall not be accepted unless such erasures or alterations have been validated by the licensing authority.
2. The extension of the validity of a licence shall not be accepted unless that extension has been validated by the licensing authority.
3. A duplicate or replacement licence shall not be accepted unless it has been issued and validated by the licensing authority.
4. A licence shall not be accepted if, where necessary after the provision of additional information in accordance with Article 3 or a further investigation in accordance with Article 4, it has been established that the licence does not correspond to the shipment.

Article 3

1. In case of doubt concerning a licence, a duplicate or a replacement licence the competent authorities may request additional information to the licensing authority of the partner country.
2. A copy of the licence, the duplicate or the replacement licence in question may be forwarded together with the request.

Article 4

1. If further verification of the shipment is considered necessary before the competent authorities can decide whether a licence can be accepted, checks may be carried out to establish whether the shipment in question conforms to the information provided in the licence and to the records relating to the relevant licence which are held by the licensing authority.
2. Where the volume or weight of the timber products contained in the shipment presented for release for free circulation does not deviate by more than 10 % from the volume or weight indicated in the corresponding licence, it shall be considered that the shipment conforms to the information provided in the licence so far as volume or weight is concerned.

Article 5

1. Reference shall be made in box 44 of the Single Administrative Document on which the customs declaration for release for free circulation is made to the number of the licence that covers the timber products subject to the declaration.

Where the customs declaration is made by means of a data-processing technique the reference shall be provided in the appropriate box.

2. Timber products shall only be released for free circulation where the procedure described in Article 1(2) has been completed.

CONDITIONS GOVERNING THE ISSUANCE AND SPECIFICATIONS OF
FLEGT LICENCES

Requirements relating to FLEGT licences

Article 1

1. A FLEGT licence may be paper-based or an electronic licence.
2. Both paper-based and electronic licences shall provide the information mentioned in Appendix 1, in accordance with the notes for guidance set out in Appendix 2.

Article 2

1. The FLEGT licence is to become valid on its actual day of issue.
2. The period of validity of the FLEGT licence shall not exceed three months. The date of expiry shall be indicated in the licence.

3. After its expiry the licence shall be considered as void. The licensing authority may decide to prolong the period of validity by one month. To that effect the licensing authority shall correct and validate the new expiry date.
4. A FLEGT licence shall cease to be valid and will be returned to the licensing authority in case the timber products covered have been destroyed.

Requirements relating to paper-based FLEGT licences

Article 3

Paper-based licences shall conform to the format set out in Appendix 1.

Article 4

1. The paper size will be standard A4. The paper will have watermarks showing the Forestry Commission logo that will be embossed on the paper in addition to the seal.
2. The colour of the paper used for the form shall be as follows:
 - (a) White for form number 1, the "Original";

- (b) Yellow for form 2, the "Copy for EU Customs Authority";
- (c) Green for form 3, the "Copy Timber Industry Development Division";
- (d) Pink for form 4, the "Copy for Ghana Customs Authority (CEPS)";
- (e) Blue for form 5, the "Copy for European Community Competent Authority".

Article 5

1. The licences shall be completed in typescript or by computerised means. They may be completed in manuscript, if necessary.
2. The stamps of the licensing authority shall be applied by means of a metal stamp, preferably made of steel. However, an embossing press combined with letters or figures obtained by means of perforation may be substituted for the licensing authority stamp. The licensing authority shall use any tamper-proof method to record the quantity allocated in such a way as to make it impossible to insert figures or references.
3. The form may not contain any erasures or alterations, unless those erasures or alterations have been authenticated by the stamp and signature of the licensing authority.

4. The licences shall be printed and completed in English.

Article 6

1. The licence shall be drawn up in 5 copies and issued to the applicant.
2. The first copy, marked "Original" shall after being completed, signed and stamped by the licensing authority be given to the applicant for submission to the Competent Authority of the EU Member State in which the shipment covered by that licence is declared for release for free circulation.
3. The second one, marked "Copy for the Customs" shall after being completed, signed and stamped by the licensing authority be given to the applicant for submission to the Customs Authority of the Member State in which the shipment covered by that licence is declared for release for free circulation.
4. The third one marked "Copy for the Timber Industry Development Division" shall after being completed, signed and stamped by the licensing authority be retained for their records and future verification on licences issued.
5. The fourth one, marked "Copy for the Ghana CEPS" shall after being completed, signed and stamped by the licensing authority be given to the applicant for submission to the Customs Authorities in Ghana for which the shipment covered by that licence is declared for release for loading on to the vessel.

6. The fifth one, marked "Copy for the EU Competent Authority" shall after being completed, signed and stamped by the licensing authority be given to the applicant for submission to the Competent Authority of the Member State in which the shipment covered by that licence is declared for release for free circulation (This copy is required where the competent authority in the Member State is different from the Customs Authority).

FLEGT licence lost, stolen, destroyed

Article 7

1. In the event of loss, theft or destruction of the "Original" or the "Copy for the Customs" the importer or his authorised representative may apply to the licensing authority for a replacement on the basis of the document in his possession.
2. In the event of loss, theft or destruction of both the "Original" and the "Copy for the Customs" the importer or his authorised representative may apply to the licensing authority for a replacement of both.
3. The licensing authority shall issue the replacement(s) within one month following the reception of the request from the importer.
4. The replacements shall contain the information and entries appearing on the licence they replace, including the licence number.

The replacing licence shall bear the endorsement "Replacement licence".

5. If the replacement licence is lost, stolen, destroyed or expired, no further replacement licence shall be issued.
6. In the event of retrieving the lost or stolen licence, the retrieved shall not be used and must be returned to the issuing authority.

Treatment of doubts regarding the validity of the licence

Article 8

1. Where in case of doubt regarding the validity of the licence or a replacement the competent authorities should request for additional information from the licensing authority.
2. If considered necessary the licensing authority may ask the competent authorities to send a copy of the licence or the replacement in question.
3. If the licensing authority considers it necessary, it shall withdraw the licence and issue a corrected copy which will include authenticated by the stamp endorsement "Duplicate" and forward it to the competent authority.

4. If the validity of the licence is confirmed, the licensing authority shall notify the competent authority forthwith, preferably by electronic means.

The copies returned shall bear the validated/authenticated by stamp endorsement "Validated on".

5. In the event that the licence in question is not valid the licensing authority shall notify the competent authority forthwith, preferably by electronic means.

Technical specifications with regard to a Computerised FLEGT licence

Article 9

1. The FLEGT licence may be issued and processed using computerised systems.
2. In EU Member States which are not linked to the computerised system a paper-based licence shall be made available.

APPENDICES

1. Licence Form.
2. Notes for guidance.

Appendix 1

Format of the FLEGT licence

Ghana emblem

1	ORIGINAL	1 Issuing authority Name		2 Importer		
		Address				
	3 FLEGT licence number		4 Date of Expiry			
	5 Country of export		7 Means of transport			
	6 ISO Code					
	8 Licensee (name and address)					
	9 Commercial description of the timber products				10 HS-Heading	
	11 Common or Scientific Names		12 Countries of harvest		13 ISO Codes	
	14 Volume (m3)		15 Net Weight (kg)		16 Number of units	
	17 Distinguishing marks					
18 Signature and stamp of issuing authority						
Place and date						

Ghana emblem

2	1 Issuing authority Name		2. Importer	
	Address			
	3 FLEGT licence number		4 Date of Expiry <div style="border: 1px solid black; width: 100px; height: 15px; margin-top: 5px;"></div>	
	5 Country of export		7 Means of transport	
	6 ISO Code			
	8 Licensee (name and address)			
	9 Commercial description of the timber products			10 HS-Heading
	11 Common or Scientific Names		12 Countries of harvest	13 ISO Codes
	14 Volume (m3)	15 Net Weight (kg)		16 Number of units
	17 Distinguishing marks			
18 Signature and stamp of issuing authority				
Place and date				

Appendix 2
Notes for Guidance

General:

- Complete in capitals.
- ISO codes, where indicated refer to the international standard two letter code for any country.

Box 1	Issuing authority	Indicate the name and address of the licensing authority.
Box 2	Importer	Name and Address of Importer.
Box 3	FLEGT licence number	Indicate the issuing number.
Box 4	Date of expiry	Period of validity of the licence.
Box 5	Country of export	This refers to the partner country from where the timber products were exported to the EU.
Box 6	ISO code	Indicate the two-letter code for the partner country referred to in Box 5.
Box 7	Means of transport	Indicate the means of transport at the point of export.
Box 8	Licensee	Indicate the name and address of the exporter.
Box 9	Commercial description	Indicate the commercial description of the timber product(s).
Box 10	HS Heading and Description	The six-digit commodity code established pursuant to the Harmonised Commodity Description and Coding System.

Box 11	Common or scientific names	Indicate the common or scientific names of the species of timber used in the product. Where more than one species is included in a composite product, use a separate line. May be omitted for a composite product or component that contains multiple species whose identity has been lost (e.g. particle board).
Box 12	Countries of harvest	Indicate the countries where the species of timber referred to in Box 10 was harvested. Where a composite product include for all sources of wood used. May be omitted for a composite product or component that contains multiple species whose identity has been lost (e.g. particle board).
Box 13	ISO codes	Indicate the ISO code of the countries referred to in box 12. May be omitted for a composite product or component that contains multiple species whose identity has been lost (e.g. particle board).
Box 14	Volume (m3)	Give the overall volume in m3. May be omitted unless the information referred to in box 15 has been omitted.
Box 15	Net Weight	Give the overall weight in kg. This is defined as the net mass of the timber products without immediate containers or any packaging, other than bearers, spacers, stickers etc. May be omitted unless the information referred to in box 15 has been omitted.
Box 16	Number of units	Indicate the number of units, where a manufactured product is best quantified in this way. May be omitted.
Box 17	Distinguishing marks	Indicate any distinguishing marks where appropriate e.g. lot number, bill of lading number. May be omitted
Box 18	Signature and stamp of issuing authority	The box shall be signed by the authorised official and stamped with the official stamp of the licensing authority. The place and data shall also be indicated.

LEGALITY ASSURANCE SYSTEM (LAS)

1. INTRODUCTION

Under the agreement, Ghana will implement a legality assurance system (LAS) which will be based on adherence to the legal definition (Annex II of the Agreement). The legal definition outlines conditions under which a product containing wood sourced and/or processed in Ghana can be licensed for sale within Ghana or for export from Ghana. For the purposes of the Agreement, the licences will cover all products exported to the EU. The products included are described in Annex I of the Agreement. A wood tracking system (WTS) will enable the establishment of a chain of custody system as well as the monitoring and reporting of compliance against the legal definition. The wood tracking system is described in Appendix 1 to 10. For the purpose of assessing compliance to the legal standard, a table that sets the legality definition against implementation of the principles and criteria is provided under the verification procedures.

Under the LAS a verification entity is to be established. This entity is called the Timber Validation Department (TVD). The TVD will perform the functions of verification. This will involve the reconciliation of data generated along the entire process chain of wood products destined for both export and the domestic market. The TVD will also measure compliance of wood consignments to the legal standard. The purpose of the verification and compliance monitoring is to enable the TVD check if procedures provided for in the legal standard have been complied with. For the purpose of performing the verification function, the TVD will work with data based on submissions and approvals from the responsible regulatory Division/Unit within the FC. The TVD to a large extent will perform the role of verification and validation of processes at the critical control point (harvesting, transportation, processing and export). The TVD will further verify and validate procedures and outputs in the Divisions. The TVD is described in the document. The figure below is a schematic presentation of the relationship of the actors in the LAS.

The LAS – Ghana

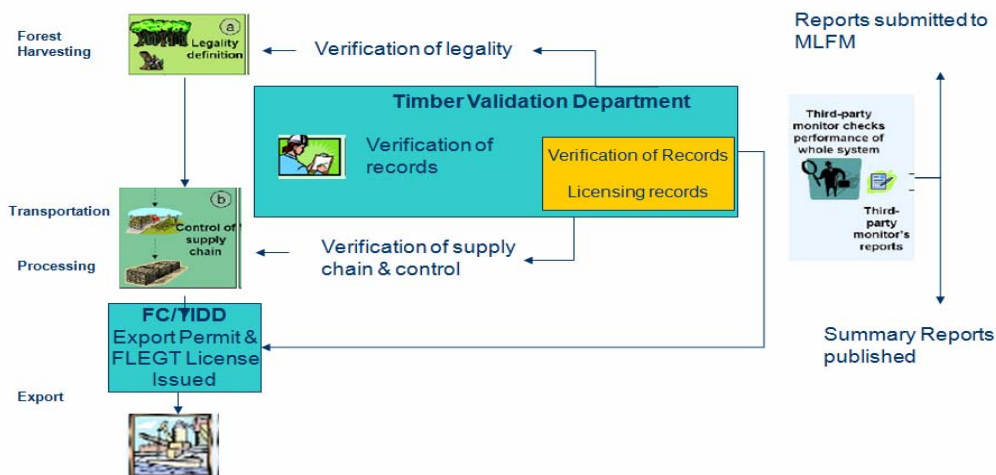

Under the new set-up the Forest Service Division will continue to regulate and manage the control interventions of the supply chain from the point of stock survey and harvest to the point of commencement of log transport. The Timber Industry Development Division (TIDD) of the Forestry Commission is the designated licensing authority under the LAS. The TIDD will issue the FLEGT licences together with export permits after it has reconciled export permit applications submitted by exporters with TVD datasets. FLEGT licences will be issued for the EU market and export permits for non-EU markets. Both will however be delivered through the LAS and therefore will be, by definition, legal timber.

The detailed procedures and management systems will be developed during the design and piloting of the LAS. The new LAS will build from existing structures and systems and seeks to address identified weaknesses in the paper-based system. This document describes the objectives and principles that will guide the development of new structures and systems.¹

Independent Monitoring and Reporting under LAS

The entire LAS will be open to external monitoring by an independent monitor (IM). The purpose of the intervention of the IM will be to identify weaknesses and recommend systemic reforms in the LAS (Terms of Reference of IM are attached as Annex VI to the Agreement).

¹ An independent review was undertaken to assess this proposal in August 2008. It identified some areas of concern that both Parties agreed would be more appropriately considered in assessing the system once it is operational. These concerns will be considered also during the design and piloting of the LAS.

2. THE WOOD TRACKING SYSTEM

Traceability of wood products from export to forest will be maintained under the agreement. In the case of products derived from wood harvested from a foreign country, the system will be able to maintain traceability from the point of entry to processing after which it will follow the same protocols as wood harvested in Ghana.

The monitoring of wood flows requires the identification of critical control points at different locations within the supply chain as well as the monitoring of stages and processes that affect the state of the asset as it moves through the chain. The first control point will be that of pre-harvest inventory data gathering. Essentially, this will involve mapping standing trees using GPS technology and gathering specific metrics data such as species and carrying out laser measuring of standing trees selected for harvest in order to accurately determine standing tree volumes. Information gathered as part of the Forest Inventory should have the option to be made available online and can be used to trigger the issuing of cutting annual permits for the harvesting of timber. This information forms the first control point within the chain of custody from which wood flows will be monitored.

The next control point (i.e. where an event occurs that affects the status of the asset) would be the felling of the tree. At this point, data would be again recorded. This process would follow throughout the forest and processing operations, monitoring timber as it transforms and flows through the supply chain and reconciling data gathered at each of the individual control points. The WTS will gather information at all the supply chain control points, process the data gathered and automatically reconcile it with data gathered at previous control points, identifying any errors or anomalies that are found in the data.

Critical Control Points

For the purpose of tracking and controlling timber flows, the following critical control points are identified and described in the supply chain:

- (i) Source of Timber
- (ii) Timber Rights Allocation
- (iii) Stock Enumeration
- (iv) Tree Felling and Log Production
- (v) Post Harvest Audit
- (vi) Log Transport and Inspections
- (vii) Confiscated Timber
- (viii) Wood Imports
- (ix) Log Arrival at Processing Plant
- (x) Log Processing
- (xi) Processed Wood
- (xii) Export of Processed Wood

1. Source of Timber and Allocation of Rights

Wood products coming from Ghana will be derived from legally designated areas and will be allocated according to legal prescription. Such products will come from designated areas within forest reserves, plantations, off-reserves areas or sub-merged forests. Timber rights will accordingly be obtained in the form of Timber Utilisation Contracts (TUCs), Salvage Permits and Plantation Felling Permits according to the provisions in the legal standard, specifically to principles 1 and 2. The controls will therefore start from the enumerated tree in these designated areas. The allocation of use rights (TUCs) are governed by procedures and the bidding sessions are conducted publicly. The record of bid winners is public. The procedures for allocating TUCs are available on the website of the FC. Additionally, public summary reports of all other use right holders (Salvage Permits, and Underwater use rights) will be indicated as an output of the verification process to increase transparency.

The timber flow control interventions are managed by the Timber Industry Development Division (TIDD) and Forest Service Division (FSD) with some level of quality control in the area of yield endorsement and post harvest audit from the Resource Management Support Centre (RMSC) of the Forestry Commission. Data along each of the control points will be reconciled by the TVD with the preceding set of data to enable traceability to be established.

The critical control points relate to the provisions in the legal definition set out in Annex II of the Agreement. They are therefore linked to the principles and criteria (as indicated in parentheses). In the operation of the electronic system, a paper based system will be used as a back-up in instances where the electronic system becomes unavailable.

2. Stock Enumeration (Relates to Principle 3 Criteria 3.1)

The Stock Enumeration is primarily managed by the Forest Service Division. The endorsement of the yield is done by the Resource Management Support Centre. The output of the process of stock enumeration is, in the first instance, a stock map. The yield list/map is a derivative of the stock map. The endorsed/approved yield is the final output that is used to conduct harvesting in the forest. All documentary outputs of this process are forwarded to Timber Validation Department (TVD) for the purposes of verification. Hand held data devices will be used to collect data in the field. The data will be downloaded at the end of the day onto FSD District office computers. From the District office, the data are then sent to the central database. The TVD central database will keep records of approved yields which will be reconciled with tree information (felled tree data) and log information (cross-cut tree data). The detailed process map for enumeration is attached in the Appendix 1.

Permission to harvest shall be enforced through the issuance of harvesting permits in the form of an administrative directive from the Forestry Commission (FSD) which will accompany an endorsed yield. The endorsed yield gives the list and location of all trees to be harvested. Record of permits for harvesting will therefore comprise of the endorsed yield and the accompanying administrative directive from the FSD.

3. Tree Felling and Log Production (Relates to Principle 3 Criteria 3.3)

The Forest Service Division (FSD) implements most of the control interventions at the point of felling and log production. Based on the inventory and the endorsed yield database, the tags to be applied on the trees stumps and logs are allocated by the FSD to the producer. These tags are applied by the producer on the stump of the felled tree as well as the logs produced. The FSD collect data on the felled tree on to the tree information form (TIF). Hand held devices will be used to enhance this function. The permission to transport the logs from the landing site is given after the FSD has issued a log measurement and conveyance certificate (LMCC) for each truck load. The LMCC is based on comparison and clearance of the log information (LIF) recorded by the producer. Copies of the tree data, log data and conveyance information are transmitted to the TVD for purposes of reconciliation. A detailed process description is given in the chart in the attached Appendix 2.

Plantation log measurement conveyance certificates (PLMCC) are issued by the FSD. For the submerged forest scenario, logs are to be marked with barcode labels of a distinctive colour in addition to paint marking to show the contractor's sequential log number. Log information forms will be filled by FSD staff at the landing showing location of origin or block number, stool, district and property mark.

4. Post Harvest Audit (Relates to Principle 3, Criteria 3.2)

Post harvest audit will be conducted by the RMSC in accordance with the harvesting plan that harvesting in the compartment is complete. The official date of opening and closure of the compartment will be held in the central database for the purposes of reconciliation. The purpose of the post harvest audit is to ensure that the operator has adhered to the harvesting plan and left the compartment in good working condition. This also provides the opportunity to check on the quality of the stock survey. Specifically, the following checks will be conducted:

- the enumeration was complete and tree diameters were correctly measured;
- the producer has only taken those trees that were in the yield list;
- the numbers, species and sizes of the logs declared correspond to the trees that were felled;
- no excessive logging damage occurred.

The report generated from the post harvest audit will be available to the FSD district office, regional office, FSD/HQ as well as the FC/HQ. The TVD will be copied for the purpose of reconciliation. The TVD will perform a sample of post harvest inspections. Appendix III shows the process map for post harvest inspections.

5. Log Transport and Inspection (Relates to Principle 4 Criteria 4.1)

The Timber Industry Development Division (TIDD) will perform unannounced checks on truckloads along the road. The unannounced checks will be done in addition to the fixed check point interventions. The log transport and inspection will check the LMCCs against truck loads. The specific checks will also ensure that all logs have tags, there is no re-use of forms, log origin corresponds to the route of the truck, the truck ID and the destination of consignment/truck. The reports of the TIDD routine checks will be captured on hand helds and transmitted to the TVD database for purposes of reconciliation. Appendix IV is the process map for log transport and inspection.

6. Confiscated Timber (Relates to Principle 2, Criteria 2.3)

Timber confiscated by the FC will only be sold by Court Order through public auctioning. After the auction the winning bidder will receive a Certificate of Purchase from the FSD. The certificate will be registered in the central database. All auctioned forest produce will be tagged. The entire auction result will be documented in a FC Sale Report and the payments due as well and entered in the central database. Process map is shown in Appendix V.

7. Imported Wood (Relates to Principle 4, Criteria 4.1)

Logs and other wood imported for processing must be declared by CEPS through GCNet platform to TIDD. Any incoming shipment will be reported to TIDD accordingly, as well as to the TVD. Export documentation will be used to verify logs sourced from outside the country. The TIDD measures the logs and puts a log tag on each one in the harbour. Other products such as lumber meant for reprocessing will similarly be tagged. The TIDD also issues the Import LMCCs (ILMCC) for the logs if these are destined for local processing plants. The logs are next loaded onto trucks and accompanied with ILMCCs to the local processing plants. Data declared is similar to that declared for logs cut in the forest and transmitted to TVD. For each imported log or wood product, records are taken of tag number, species, length and two diameters at each end. For each truckload the LMCC, importer ID, country of origin, destination, processing company ID, truck ID, driver and truck owner are recorded. The wood then follows a similar supply chain management process as wood harvested in Ghana. Process map is shown in Appendix VI.

8. Log Arrival at Processing Plant (Relates to Principle 5)

Daily declaration will be required of the producer on arrival of the logs at the processing plant. These declarations will include the location, date/time, LMCC form number and truck ID of all arriving consignments. The LSEs with considerable size log yard will be required to indicate the location of each log in the yard after loading. This record will be amended each time the log changes location. TIDD checks will ensure that all logs bear tags and that the information on the tag matches the declared records. Records of remanufactured logs must also be kept and declared. Data captured at log arrivals at the processing plant will be made available to the TVD. This data on log arrivals will be reconciled with the LIFs and the LMCCs. Appendix VII is the process map for log arrival at processing plant.

9. Log Processing – Shift Records – (Relates to Principle 5)

At the end of shift the sawmill/processing company will make a declaration of the list of logs and log pieces which were processed during the shift. The following records will be provided: date, processing plant ID, log tag numbers, quantities of processed wood and respective processing contract ID. The system must be able to tally the pieces of wood that come from each log or log piece, so that for a particular bundle of processed wood the constituent logs can be identified. Conversion factors will be dependent on the diameter, species, and quality etc. of the input logs and this critical element of the WTS that will enable effective reconciliation will be further developed in the pilot phase. TIDD inspectors will oversee the data collection process to ensure that records are being kept correctly and accurately. Random inspections and the days/shifts of inspection will be recorded so that results can be checked against days when no inspectors are present. Records of the shift production as submitted by the producer will be made available to the central database for the purpose of reconciliation. This will include monthly stocks of processed logs and processed wood products. Appendix VIII shows the business processes for log processing.

10. Processed Wood (Relates to Principle 5)

Processed wood bundles when completed will be marked with a processed wood tag. TIDD inspectors will perform checks before the consignments are loaded into containers/trucks. Every truck will have a numbered way bill. Data for each processed wood bundle includes tag number, type, species, volume, no. of pieces, contract number, destination and waybill number and list of logs used to make the bundle. The checks performed by TIDD will ensure that the data provided matches the physical consignments on the truck. Records will be made available to the TVD to enable reconciliation between processed wood inspections and declarations. This will determine whether producers are declaring their production correctly. Monthly reports will be available to the FC and TIDD HQs. Appendix IX is the business process map for processed wood.

11. Export of Processed Wood Bundles (Relates to Principle 5)

To enable the export of processed wood bundles, the exporters will submit a request (using a web form) for the export of a contract ID of processed wood, with details of purchaser ID, destination ID, shipping date, ship name. There will be the provision of manual submission of records as a back up to the electronic system. This will consist of a list of processed wood bundle tag numbers, showing type of product, volume, species, grade etc, along with information on the sales contract, buyer, etc. The central database will receive the list of bundle tag numbers and produce a report indicating the history of the wood in those bundles, showing when and where processing was done, the ID numbers of the logs and the IDs and locations of the source trees involved, when and where the source trees were cut (a digital map of source trees should be available on the web), and the results of FC/TVD sampled inspections (volume and species disparities). The random inspections refer to the TVD post harvest audit sampled inspections. If no discrepancies over an agreed threshold are found, the "go-ahead" is given to the TIDD for the issuance of the FLEGT licences.

Details of product export certificates issued are stored in the database (authoriser's name, certificate number, volume, species, type of product, date of issue, exporter, purchaser, etc.). At the time of contract approval the TIDD will enter into the system the relevant details: contract number, buyer ID (overseas), processing company ID, volumes/dimensions to be supplied (by species and product ID). Details of transactions under export of wood bundles are shown in Appendix X.

Table 1 overleaf is a summary description of the procedures for tracking wood from stock enumeration through felling, cross-cutting of logs, conversion into primary and secondary products and export.

Table 1: Data Reconciliation along the Process Chain.

Activity	Output	Data source	Reconciliation	Key data
Enumeration	Stock List/Map	FC/Private		Stock no, Species, Locality Mark, Property Mark.
↓				
Yield selection	Yield List/Map	FC		Stock no, Species, Locality Mark, Property Mark.
↓				
Yield endorsement	Yield List/Map	RMSC	Stock List, Yield List	Stock no, Species, Locality Mark, Property Mark.
↓				
Post-felling insp.	Felled tree list (TIF)	RMSC/TVD	Yield List, TIFs	Stock no, tree tag no.
↓				
Log produced and transported	Log (LIF) data (declaration), LMCC	FSD/Log Producer	TIF, LIF, LMCC	Log tag no, LMCCs.
↓				
Roadside Log Inspection	Log data (inspection)	TIDD (HHC)	LMCCs and Truck Loads	Log tag no, LMCC no., Truck ID.
↓				
Log yard	Log arrival	Primary Processor TIDD	Against log declaration, LMCC, Truck ID.	Log tag no, LMCC, Truck ID.
↓				

Activity	Output	Data source	Reconciliation	Key data
Log converted	Log conversion	Primary Processor	Processed Logs, Output Vol./Species,	Log tag no., Contract no.
↓				
Primary PW transported	PW data (declaration)	Primary Processor	Against logs converted	Log tag no. Primary PW tag no., Contract no.
↓				
Primary PW inspected	PW data (inspection)	TIDD (HHC)	Against primary PW declaration	Primary PW tag no.
↓				
Primary PW exported	PW arrival (at port)	Exporter	Against declared waybill no.	Primary PW tag no. Export dossier no.
Or ... arrival at secondary mill	Processed wood Arrival	Secondary Processor	Against Primary PW declaration	Primary PW tag no. Contract no.
↓				
Secondary PW transported	PW data (declaration)	Secondary Processor	Against primary PW converted	Secondary PW tag no.
↓				
Secondary PW inspected	PW data (inspection)	TIDD (HHC)	Against secondary PW declaration	Secondary PW tag no.
↓				
Secondary PW exported	PW arrival (at port)	Exporter TIDD/TVD	Complete history	Secondary PW tag no. Export dossier no.

3. VERIFICATION PROCEDURE

This section sets out the legality definition against implementation of the principles and criteria. The procedures as will be implemented by the concerned agencies are outlined. Table 2 therefore indicates the control procedures by responsible FC divisions. The outputs of the control procedures will be verified under the protocols to be developed under the LAS pilot phase. Mechanisms for handling non-compliance identified over the course of verification activities will be developed in detail in the pilot phase based on existing law enforcement procedures and regulation.

Verification methodology which will specify the periodicity, sampling methods, field procedures and collection of objective evidence will be addressed in the TVD manual of procedures. This table takes its source from the definition of legal timber in Annex II of the Agreement.

Table 2: Control Procedures against Principles and Criteria

PRINCIPLE 1	Source of Timber: Timber originated from prescribed sources and the concerned individual, group and owners gave their written consent to the land being subjected to the grant of timber rights.
CRITERION 1.1	<p>For TUCs in on-reserves, forest management plan preparation covers strategic plan;</p> <p>Delineation of TUC;</p> <p>Conduct of an inventory by FSD before harvesting (on-reserve, off-reserve and plantation);</p> <p>Written consent of concerned individual, group or owners.</p>
RESPONSIBILITY	<ul style="list-style-type: none"> • FSD responsible for strategic and operational planning of on-reserve TUCs. RMSC – Quality Control of Enumeration; Endorsement of Yield; • TIDD to verify import documentation for imported wood products and produce reports.

PROCEDURE	<p><u>On-reserve</u></p> <p><u>Strategic management plans</u></p> <ul style="list-style-type: none"> • formation of planning team; • review of current situation based on existing information; • provisional zonation; • field investigations; • provisional management planning for each zone; • compilation of a first draft management plan; • formal review of working draft by resource owners; • revision of the working draft; • local endorsement of the draft plan; • forward the draft plan for national review and approval; • publish and circulate copies of the final plan; • prepare summary pamphlet of the plan. <p><u>Delineation of TUC</u></p> <ul style="list-style-type: none"> • Fixing of boundary pillar by FSD; • Cleaning of boundaries by FSD. <p><u>Written consent</u></p> <p>Post of notices at (a) the offices of the District Assembly, Traditional Council and Unit area in whose area of authority the land identified is situated for 21 days.</p> <p>Concerned individual, group or owner notifies his interest and consents in writing to FC of the land being subjected to grant of timber rights.</p>
-----------	--

	<p><u>Inventory</u></p> <ul style="list-style-type: none">• Stock enumeration by FC for SMEs. LSEs to conduct enumeration in their TUC areas;• Verification of the quality of enumeration and clearance is the responsibility of FC(RMSC);• Digitise Yield List and Yield Map produced; a shared responsibility by FC/Enterprise;• Vetting and endorsement of the proposed yield thoroughly carried out by FC- (RMSC);• RMSC lodges copies of approved yield with FSD, TIDD and TVD. In the case of enterprise copy of yield is routed through FSD under a cover letter that states salient FC logging rules;• RMSC endorses and enters yield (key element of the WTS) into central database;• FSD approves and enters yield into database.
--	---

off-reserve

Operational plan and inventory

- Endorsement and modification, if necessary, of the draft TUC operational plan (FC-FSD);
- Initial selection of trees by contractor (enterprise);
- Conduct Pre-felling Inspection by taking GPS bearings of all trees to be harvested in the OFRs (FC-FSD);
- Recording of parameters (FC-FSD);
- Yield selection and approval (FC-FSD);
- Preparation of annual logging plan;
- FSD release copy of approved yield to Enterprise and TVD;
- FSD enters approved yield into central database.

Delineation

- field checks of unallocated land by FSD;
- Boundaries if possible follow undisputed land ownership boundaries and distinct natural features (rivers, roads, etc.);
- identify areas that need to be excluded and fixing of boundaries by FSD;
- Demarcation on a map and supported with a description of the boundaries by FSD.

Written consent

- Consultation with communities, District Chief Executive (DCE) or their accredited representative;
- Field inspection of the potential harvesting area with the land owners consent.

Plantation

- Enumeration of all harvestable trees (FC-FSD);
- Estimate standing tree volume (FC-FSD);
- Upfront payment by contract (ENTERPRISE);
- Issuance of entry permit (FC-FSD);
- FSD release copy of entry permit to Enterprise and TVD;
- FSD enters details of entry permit stating the estimated standing volume into its central database.

Delineation

All plantations within forests reserves have their compartment boundaries mapped by the FC

FSD District plantation unit marks boundaries (e.g. by cleaning, by oil paints),

Underwater

Pre-defined block number underwater (FC-FSD/ENTERPRISE).

Imported wood

- Enterprise ensure that wood imported are declared through CEPS GCNet platform to TIDD;
- Any incoming shipment must be reported to TIDD;
- FC-TIDD ensures that all imported wood are legally sourced from the country of origin and have appropriate documentation. This will be done through checks on import documentation.

OUTPUT	<p><u>On-reserve</u></p> <ul style="list-style-type: none"> • Forest Management documents; • Forest maps; • Forest Survey Reports, stock enumeration and yield data; • Maps of Forest types (habitats critical areas, genetic hot spots, Globally Significant Biodiversity Areas, Coarse grained protection areas); • Reserve Management Plan. <p><u>Off-reserve</u></p> <ul style="list-style-type: none"> • Operational plan; • TUC Map; • Off-reserve Inventory Report; • felling Inspection Form CO2; • Felling Permit Form CO3/Letter of approval. <p><u>Plantation</u></p> <ul style="list-style-type: none"> • Plantation Map; • Enumeration report; • Payment receipt; • Entry permit. <p><u>Underwater</u></p> <ul style="list-style-type: none"> • Blocking report. <p><u>Imported wood</u></p> <p>Declaration to Customs of Imported Timber (GCNet report); importer ID, Country of origin, etc.</p>
--------	--

PRINCIPLE 1	Source of Timber: Timber originated from prescribed sources and concerned individual, group and owners gave their written consent to the land being subjected to the grant of timber rights.
CRITERION 1.2	Land owners/individual/group consent.
RESPONSIBILITY	<ul style="list-style-type: none"> • FC-FSD checks on Public notification through districts quarterly reports.
PROCEDURE	<p><u>On-reserve</u></p> <ul style="list-style-type: none"> • Consent embodied in the reserve management plan (FC-FSD). <p><u>Off-reserve</u></p> <ul style="list-style-type: none"> • Land owner and affected farmer(s) identified through District Assembly, Traditional Council, Unit area, District Forest Office as part of the consultation process; • Constitute field inspection team as stated by law (FC-FSD); • Any tenure disputes resolved through arbitration (FC-FSD); • Local stakeholders (e.g. land owners, affected farmers) consented in writing to harvesting of the resource.
OUTPUT	<ul style="list-style-type: none"> • District Notices; • Written consent; • Consultation Minutes; • Records Arbitration of Proceedings.

PRINCIPLE 2	<p><u>Timber Rights Allocation</u></p> <p>The logger held a TUC issued by the Minister and ratified by Parliament following the specified competitive process or Logger held a SP issued by the Forestry Commission.</p>
-------------	--

CRITERION 2.1	<u>Natural Forest and Plantation TUCs</u> Qualification of loggers by TREC.
RESPONSIBILITY	MLFM, TREC and FC.
PROCEDURE	<ul style="list-style-type: none"> • Logger participates in competitive bidding process; • The Forestry Commission recommends to MLFM to award a TUC to Logger; • Logger complies with all conditions specified in Minister's notice of award under the Act. This includes a secured consent from concerned individual, group or landowner; • The Minister executes the TUC in the prescribed format; • Parliament ratifies TUCs (with the exception of plantation TUCs).
OUTPUT	<ul style="list-style-type: none"> • TREC pre-qualification report; • Letter of Consent; • TREC bidding report; • FC report to MLFM on compliance; • TUC; • TUC and Parliamentary Hansard (Except plantation TUC).

PRINCIPLE 2	<u>Timber Rights Allocation</u> The logger held a TUC issued by the Minister and ratified by Parliament following the specified competitive process or Logger held a SP issued by the Forestry Commission.
-------------	---

CRITERION 2.2	<u>Salvage permit</u> ¹ Issuance of Salvage Permit.
RESPONSIBILITY	FC-HQ.
PROCEDURE	<ul style="list-style-type: none"> • Enterprise applies to FC; • FSD conducts inspection and submits a report to CEO of FC about the justification for commercial trees in a defined location to be salvaged; • FC issues salvage permit; • FSD enters details of salvage permit into the central database.
OUTPUT	<ul style="list-style-type: none"> • Applicant's application; • FSD's inspection report; • Salvage permit.

PRINCIPLE 2	<u>Timber Rights Allocation</u> The logger held a TUC issued by the Minister and ratified by Parliament following the specified competitive process or Logger held a SP issued by the Forestry Commission.
CRITERION 3	Confiscated Timber.
RESPONSIBILITY	FC-FSD.
PROCEDURE	<ul style="list-style-type: none"> • FC determines the offence and court authorises the sale of confiscated timber product; • COP issued to the buyer according to statute; due process for auctioning confiscated timber are followed.
OUTPUT	<ul style="list-style-type: none"> • Court Order; • Certificate of Purchase; • FC sale report.

¹ Forestry Commission issue a permit subjected to such terms and conditions as shall be specified therein for the salvage of trees from an area of land undergoing development such as road construction, expansion of human settlement or cultivation of farms.

PRINCIPLE 3	<p><u>Timber Harvesting Operations</u></p> <p>The logger complied with forest operation procedures and standards specified by statute.</p>
CRITERION 3.1	<p>Stock surveys (including pre-felling inspections for off-reserve areas) were conducted in accordance with the logging manual.</p> <p>Harvesting plan preparation.</p>
RESPONSIBILITY	<ul style="list-style-type: none"> • FC-FSD (validates harvesting plan submitted by industry); • RMSC (checks that allocated yield conforms to MoP requirements).
PROCEDURE	<p><u>Stock Survey</u></p> <p>Refer to procedure under criterion 1.1.</p> <p><u>Harvesting plan (forest reserve)</u></p> <p>Complete the approved compartment logging plan format which includes:</p> <ul style="list-style-type: none"> • general description of compartment; • propose start and finish date of harvesting; • road/track construction; • total length of skidding tracks needed; • scaled map ($\geq 1:10,000$) showing the following: <ul style="list-style-type: none"> – protected areas to be excluded from timber production; – all water courses; – position of existing and new tracks to be constructed; – log dumps.

	<p><u>Harvesting plan (off- reserve)</u></p> <ul style="list-style-type: none"> • detailed description of the harvest area including delineated boundaries of the area; • summary of number of trees agreed for felling as per pre-felling inspection form-CO₂; • road/track construction; • total length of skidding tracks needed; • scaled map($\geq 1:25,000$) showing the following: <ul style="list-style-type: none"> – protected areas to be excluded from timber production; – all water courses; – position of existing and new tracks to be constructed. • Agreement plans with affected farmers/communities in course of track construction.
	<p><u>Harvesting</u></p> <ul style="list-style-type: none"> • In forest reserves, range supervisor records tree parameter; • The operator record tree parameter in off-reserves; • Records tree data onto TIF; • Scans tag (barcode) number; • Marks tree stump/tag stump; • Cross-cut tree into logs.

OUTPUT	<ul style="list-style-type: none"> • Harvesting schedule; • Stock survey report; • Pre-felling inspection report; • Stocking maps; • Yield Lists; • Yield maps.
PRINCIPLE 3	<p><u>Timber Harvesting Operations</u></p> <p>The logger complied with forest operation procedures and standards specified by statute (LI 1649).</p>
CRITERION 3.2	<p>Logging was carried out in accordance with harvesting requirements in areas designated for timber production.</p>
RESPONSIBILITY	<ul style="list-style-type: none"> • FC-FSD (Checks logging by Enterprises; check numbering and tagging of stumps; checks environmental impacts in accordance with logging manual (i.e. buffer strips, etc.)); • RMSC (conducts stock survey checks).

PROCEDURE	<p>Logger notifies the District Office of completion of harvesting in a compartment.</p> <p>FSD carry out a detailed 100 % post-felling inspection in the compartment harvested.</p> <p>FSD checks Enterprise for adherence to harvesting standards/specifications as spelled out in the logging manual.</p> <p>In cases where enterprise conducted stock survey, RMSC check on the accuracy of stock survey.</p> <p>The logger (Enterprise) checks that all stumps trees have a numbered tree tag on them.</p> <p>Both FSD and Enterprise ensure that all trees listed as approved in the yield have been extracted and all fees, royalties and compensation paid:</p> <ul style="list-style-type: none"> • Enterprise ensures that Log yards have been ripped to break up compacted soil; • Enterprise ensures that all rubbish/debris removed from site; • All streams and water courses clear of debris; • Ensures that all access and skidding tracks follow the agreed alignment and adequate drainage is provided; • Good felling practice is observed; • FSD ensures that all relevant data is captured using hand-held computers for onward transmission to TVD.
-----------	---

	<p>Environmental standards</p> <p>Enterprise ensures the following:</p> <ul style="list-style-type: none"> • Siltation of water courses is avoided to prevent water pollution; • No logging operation is permitted within a buffer strip, 25 meters either side of any stream or 50 meters either side of a river; • No smoking is permitted during high fire hazard periods except on a road way cleared of inflammable material; • No logging operation, including felling, skidding, road and log yard construction is permitted in a protected area; • Any tree classified as Black Star (species of important international interest and conservation value) cannot be felled under any circumstance; for special permit species an authorisation is required from RMSC.
OUTPUT	<ul style="list-style-type: none"> • RMSC Post harvest audit report; • Compartment Closure Certificate.

PRINCIPLE	<p><u>Timber Harvesting Operations</u></p> <p>The logger complied with forest operation procedures and standards specified by statute.</p>
CRITERION 3.3	Logs were accurately measured and recorded.
RESPONSIBILITY	<ul style="list-style-type: none"> • FC-FSD (verifies LIF recordings and verifies tagging on logs and stumps); • TIDD (randomly measures logs at check points).

PROCEDURE	<ul style="list-style-type: none"> • FSD Range supervisor take full measurement of felled tress; • Records tree parameter on Tree Information Form (TIF); • The logger (Enterprise) records log parameters including log tag number on Log Information Form (LIF); • FC-TVD issue tags to FC-FSD and Enterprise according to permitted yield; • FSD cross-check TIF data with LIF from Enterprise; • FSD verify log data and Tag number.
OUTPUT	Completed TIF and LIF.

PRINCIPLE 3	<u>Timber Harvesting Operations</u> The logger complied with forest operation procedures and standards specified by statute.
CRITERION 3.4	Timber harvested corresponded to the species and volumes or numbers authorised in the TUC or Salvage permit.
RESPONSIBILITY	<ul style="list-style-type: none"> • FC-FSD (checks species and volume declaration on TIF and LIF; checks harvests against Yield).
PROCEDURE	<ul style="list-style-type: none"> • The producer records the log data, including log tag number, number of log(s) from the tree, dimensions (length plus two diameters at each end), species, tree (stump) tag number, tree stock number, onto the LIF form; • FC and Enterprise check that all tree stumps tagging and numbering are conducted; appropriate tag colour on them; • FSD cross-check TIF data with LIF from Enterprise; • FSD verify log data and Tag number.
OUTPUT	<ul style="list-style-type: none"> • Yield; • Completed TIF and LIF.

PRINCIPLE 3	<p><u>Timber Harvesting Operations</u></p> <p>The logger complied with forest operation procedures and standards specified by statute.</p>
CRITERION 3.5	Stumps and logs were marked and numbered in accordance with the logging manual.
RESPONSIBILITY	<ul style="list-style-type: none"> • FC-FSD (checks markings and tagging); • TIDD (checks marking on logs at check points).
PROCEDURE	<p>FC and Enterprise ensures that:</p> <ul style="list-style-type: none"> • All tree stumps are marked and numbered; • Every log must be marked with: <ul style="list-style-type: none"> – the species code, locality mark, contractor's tree number, which is sequential numbering beginning with 1 (i.e. number of trees felled since registration of enterprise's property mark; – Log number which is the number of the log cut from the tree; log number 1 is the butt log; – The enterprise's property mark. • Logs from within forest reserves must be marked with: <ul style="list-style-type: none"> – Reserve code, compartment and stock survey number. • Logs from off-reserve must be marked with the code "OFR"; • Tree stumps/logs have appropriate tag colour on them.
OUTPUT	Marked and Tagged stumps, marked and tagged logs.

PRINCIPLE 3	<u>Timber Harvesting Operations</u> The logger complied with forest operation procedures and standards specified by statute.
CRITERION 3.6	The logger executed and complied with the relevant Social Responsibility Agreement.
RESPONSIBILITY	FC-FSD checks compliance on SRA.
PROCEDURE	<ul style="list-style-type: none"> • FC-FSD ensures that logger enters into an SRA with land owning communities and it forms an integral part of the TUC and terms and conditions becomes binding on both parties; • Enterprise deposits SRA document with FC; • FC-FSD report on compliance of the SRA; • Land owning communities respect the right of the logger to be able to operate in the TUC area.
OUTPUT	SRA document; FSD reports on compliance.

PRINCIPLE 3	<u>Timber Harvesting Operations</u> The logger complied with forest operation procedures and standards specified by statute.
CRITERION 3.7	Compensation was paid to affected farmers in respect of crop damage if any.
RESPONSIBILITY	FC-FSD checks compensation level and payment.
PROCEDURE	<ul style="list-style-type: none"> • FSD conducts damage assessment as specified in the Logging Manual; • FSD ensures that logger (Enterprise) pay the appropriate compensation payment in respect of crops damaged.
OUTPUT	Damage assessment and compensation report and payment receipt.

PRINCIPLE 4	<p><u>Transportation</u></p> <p>Timber was at all times transported in accordance with standards prescribed by statute.</p>
CRITERION 4.1	Timber was transported with official documentation detailing its origin and corresponding with physical identification of the timber.
RESPONSIBILITY	TIDD (checks on LMCCs/PLMCC/ILMCC and submits data to TVD).
PROCEDURE	<ul style="list-style-type: none"> • Enterprise applies for LMCC/PLMCC from FC-FSD; • FC-FSD checks TIF details against log declarations (LIF and Log tag No.); • FC-FSD issues LMCC/PLMCC for truck movement to destination (mills); • FC-TIDD conducts road side checks at designated check points and TIDD inspectors perform unannounced checks on sampled truck load; i.e. LMCC/PLMCC checked against logs on truck (details of check include property mark, locality mark, stock survey number, truck ID, destination, etc.); • FC-TIDD checks and capture LMCC/PLMCC data at designated check points using Hand-held computers and transmit data to TVD central data base; • Upon arrival at mills, details of logs are entered in Mill Log Book. <p>Transportation (Imported timber)</p> <ul style="list-style-type: none"> • TIDD measures the wood and puts a tag on each of the logs/bundles at the harbour; • Logs destined for local processing plants are loaded unto trucks and TIDD issues ILMCC; • Data declared is similar to that declared for logs cut in the forest and transmitted to TVD. This includes tag number, species, length and two diameters at each end. For each truckload the LIF number, importer ID, country of origin, destination, processing company ID, truck ID, driver and truck owner are recorded.
OUTPUT	LMCC/PLMCC, ILMCC, Waybill, Details of logs recorded in Mill Log Book.

PRINCIPLE 4	<u>Transportation</u> Timber was at all times transported in accordance with standards prescribed by statute.
CRITERION 4.2	Timber was transported within the periods permitted by law.
RESPONSIBILITY	FC-TIDD (checks on truck movements).
PROCEDURE	FC-TIDD and FC-FSD ensures that timber is transported between 6:00 am and 6:00 pm on a working day unless otherwise permitted by the Chief Executive on an application to him for the purpose.
OUTPUT	LMCC/PLMCC/ILMCC.

PRINCIPLE 5	<u>Processing</u>
CRITERION 5.1	Timber processing facilities have valid licences and registration with FC and complied with all legal requirements.
RESPONSIBILITY	FC-TIDD (check documents submitted by Enterprise; checks source of raw material of Enterprise).
PROCEDURE	<p><u>New enterprises:</u></p> <ul style="list-style-type: none"> • Enterprise submits application to FC of its intent to start a Timber Enterprise; • FC-TIDD check the required documents (Business plan and feasibility report, including source of raw material); • FC-TIDD register the enterprise and issue certificate if all requirements are met. <p><u>Existing enterprises</u></p> <ul style="list-style-type: none"> • Enterprise submits application to FC for renewal of their licence annually; • FC-TIDD check the required documents (Company's code and certificate to commence business obtainable from Registrar General's Office; Tax clearance from Internal Revenue Service; Property Mark renewal from FC-FSD); • FC-TIDD renews certificate if all requirements are met.
OUTPUT	Valid certificate/licence.

PRINCIPLE 5	<u>Processing</u>
CRITERION 5.2	Industrial relation practices conform to legal standards.
RESPONSIBILITY	<ul style="list-style-type: none"> • TIDD (checks labour, health and safety requirements); • Factory Inspectorate Unit (Labour Department).
PROCEDURE	<p>Enterprise ensures that :</p> <ul style="list-style-type: none"> • every worker employed works under satisfactory safe and healthy conditions; • workers are provided with the necessary information, instructions and training about health and safety at their place of work; • adequate precautionary measures are in place to provide worker safety in the event of fire; • there is prevention of accidents and injury to health arising out of, connected with, or occurring in the course of, work by minimising the causes of hazards inherent in the working environment; • Workmen compensation insurance exists for all workers; • Labour department conducts inspection and or direct employer to put in place the necessary corrective measures to ensure health and safety at work place.
OUTPUT	Work instructions, training, insurance and accident records.

PRINCIPLE 6	<u>Trade</u>
	All vendors/exporters have valid licence or permits to market timber.
CRITERION 6.1	Exporters have acquired FC permit.
RESPONSIBILITY	FC-TIDD.

PROCEDURE	<ul style="list-style-type: none"> • Buyer applies for inspection; • Exporter submit tax clearance certificate; • TIDD issue inspection report; • Reconciliation of data by TIDD; • FC-TIDD conducts Input and output reconciliation • Export is preceded by an exporter submitting a request in a web form or manually for the export of a contract ID of processed wood. The contract approval process then follows: • At the time of export, TIDD will enter into the TVD data base system details such as processing company ID, Contract number, buyer ID, volumes and dimensions to be supplied by species and product ID etc.; • TIDD will issue reports on monthly exports of processed timber products for each producer or exporter; • The central database at TVD will receive the list of bundle tag numbers and produce a report indicating the history of the wood in some sampled bundles; showing when and where processing was done, the ID numbers of the logs and the IDs and locations of the source trees involved, when and where the source trees were cut etc; • After a successful reconciliation of acceptable data sets, TVD will issue the record of verification to TIDD. TIDD issues Export/FLEGT licence; • TIDD transmits data to CEPS for release of cargo for loading on the vessel. • CEPS release for export.
-----------	---

OUTPUT	<ul style="list-style-type: none"> • Buyers Registration Certificate; • FC Certificates/Licence to operate; • FC-TIDD approved sales contract; • CLC; • Tax clearance certificate, Product inspection report, CLC and Custom clearance.
PRINCIPLE 6	<p><u>Trade</u></p> <p>All vendors/exporters have valid licence or permits to market timber.</p>
CRITERION 6.2	Domestic Vendors have FC registration.
RESPONSIBILITY	FC-TIDD (checks on applications for registration by domestic vendors; checks on Vendor sites; checks Vendor purchases from Saw Mills).
PROCEDURE	<ul style="list-style-type: none"> • Vendor applies for inspection; • Vendor submits tax clearance certificate; • Issuance of inspection report by FC-TIDD; • Reconciliation of data by FC-TIDD; • FC-TIDD Input and output reconciliation; • TIDD will in future issue reports on monthly supply to domestic market of processed timber products for each producer.

OUTPUT	<ul style="list-style-type: none"> • Vendor's valid FC registration licence; • FC Certificates/Licence to operate; • Product inspection report; • VAT registration certificate; • Income tax clearance certificate.
PRINCIPLE 7	<p><u>Fiscal Obligations</u></p> <p>Neither the logger nor the Vendor was at the time of sale or export in default of fees, rents or taxes, prescribed by statute.</p>
CRITERION 7.1	<p>Logger was not in default of stumpage fees or any other fees payable by loggers in Ghana.</p>
RESPONSIBILITY	<ul style="list-style-type: none"> • TIDD (checks payment of stumpage and other fees prior to issuance of FLEGT licence); • FC-FSD (checks on payment of stumpage prior to renewal of Property Mark); • TREC (checks payments of stumpage prior to pre-qualification of bidders for competitive bidding);

PROCEDURE	<p>Range supervisors generates weekly billing reports based on TIF.</p> <p>Forest District Accountant prepares contractor's bill.</p> <p>Weekly contract bill/statement of account submitted.</p> <p>FC-FSD will issue reports on analysis of royalty invoices based on timber production for each producer.</p> <p>TIDD conducts reconciliation of financial flows. For exporters this will include:</p> <ul style="list-style-type: none"> • Stumpage fees; • Approved Bank of Ghana Exchange control form A2; • Evidence of payments of letters of credit.
OUTPUT	Contractor's bill, payment receipts Exchange control Form A2, Letters of Credit.

PRINCIPLE 7	<p><u>Fiscal Obligations</u></p> <p>Neither the logger nor the Vendor was at the time of sale or export in default of fees, rents or taxes, prescribed by statute.</p>
CRITERION 7.2	Logger was not in default of ground rents.
RESPONSIBILITY	FC-FSD (checks on ground rent payment).
PROCEDURE	FC-FSD sends contractors monthly statements.
OUTPUT	FSD contractors' monthly statement, payment receipts.

PRINCIPLE 7	<p><u>Fiscal Obligations</u></p> <p>Neither the logger nor the Vendor was at the time of sale or export in default of fees, rents or taxes, prescribed by statute.</p>
CRITERION 7.3	Exporter was not in default of export levies.
RESPONSIBILITY	-TIDD (checks on payment of export levies prior to registration and issuance of FLEGT licences).

PROCEDURE	<ul style="list-style-type: none"> • Exporter presents export documentation; • TIDD determines which species attracts levy; • Exporter pays; • FC-TIDD issues permit; • FC-TIDD provides quarterly reports to MLFM, MFEP, Accountant General.
OUTPUT	Payment receipts and FC-TIDD monthly quarterly reports.

PRINCIPLE 7	<u>Fiscal Obligations</u> Neither the logger nor the Vendor was at the time of sale or export in default of fees, rents or taxes, prescribed by statute.
CRITERION 7.4	Neither Logger nor exporter was in default of corporate income tax.
RESPONSIBILITY	<ul style="list-style-type: none"> • FSD (checks income tax payments prior to property mark registration and allocation of resources); • TIDD (checks income tax prior to registration of exporters/domestic vendors of wood products).
PROCEDURE	Exporter or vendors submits income tax clearance certificates during property mark registration or renewal and registration with TIDD or renewal of certificate.
OUTPUT	Tax clearance certificate, Payment receipts.

4. LICENSING PROCEDURE

As the designated licensing authority, TIDD will be responsible for issuing licences for all consignments. TIDD will rely on information from TVD confirming legal compliance of the shipment in question. The detailed management and licence issuance procedures will be developed during the pilot phase and will build on the existing TIDD procedures for permit issuance. The system will thus enable TIDD to issue consignment based licences to be issued for wood products exported against the legality definition. Data to be reconciled along the process chain is laid out in Table 1 as well as verification of procedures in Table 2.

At operational level, TIDD will reconcile the following: verification of documentation including production declarations and permits; field inspections to ensure compliance with the documented record; log and timber product tracking from source to point of export; verification of royalty and other payments; and random checks on logging areas, truck loads and processing plants. These checks will be supported by the TVD clearance to allow for issuance of the FLEGT licence. This will further be developed at the piloting stage.

The FLEGT licensing authority will have access to reconciled data at the various control points to enable it issue the licences. Licences issued by the authority will be randomly checked by the TVD to ensure that only export parcels that have complied with the legal requirements for sourcing harvest, transport, processing, trade and meeting its financial/tax obligations.

5. THE TIMBER VALIDATION DEPARTMENT (TVD)

1. Introduction

In the implementation of the LAS it is important that the principles of independence, transparency and credibility are respected. In this regard, a Timber Validation Department (TVD) will be created to perform the following functions:

- (i) Auditor in the operations of actors in the forestry sector. In this respect it will check on the status of implementation of regulatory function as prescribed the law and contained in the definition of legality framework. The TVD will use the verification procedures as outlined in Table 2 as the audit framework to guide the discharge of its verification functions;
- (ii) Reconciliation of datasets generated through field operations within the sector for the purpose of enabling the issuance system based licences.

Technical assistance will be sought to establish the management systems and verification protocols of the TVD as well as to provide a basis for establishing credibility of the LAS. This will also serve as a basis for building capacity.

2. Institutional arrangement and staffing

The TVD will be established as a department within the FC and based at the HQ. The Secretariat of the VPA will form the nucleus of the new TVD and will be headed by a Director who shall be appointed through a competitive recruitment process. To encourage the introduction of new working culture, the TVD will to a large extent recruit personnel to fill vacancies during the pilot phase. A similar approach will be used beyond the pilot phase when the system is fully functional. Key personnel for the TVD will have to be graduates with strong background in ICT, Forestry, Wood Technology and Supply Chain Management. Key functions of the TVD shall include – reporting on infractions and make recommendations for improvement on the LAS and the regulatory framework to the Ministry of Lands, Forestry and Mines through the Chief Executive. To ensure empowerment of the TVD, the MLFM will introduce an LI as part of the first phase of reforms under the legislative review.

To ensure maintenance of high-calibre staff, the Director will be tasked to develop a program for training of the TVD staff. This will ensure that the skills of the TVD staff are continuously upgraded to keep in sync with the demands of the system.

To ensure independence and credibility, a Timber Validation Council (TVC) will be established to have oversight for the functioning of the TVD. The Council will ensure that the TVD functions in a transparent and independent manner. The Council will be made up of different stakeholders as indicated, but not limited, to the following:

- (i) Judiciary
- (ii) Ministry of Lands, Forestry and Mines
- (iii) Customs
- (iv) Police
- (v) Civil Society
- (vi) Chief Executive of the FC
- (vii) Industry
- (viii) Director of TVD as ex-officio member

The Council shall be chaired by the Chief Executive of FC. Heads of FC agencies may be invited for meetings where a subject matter resides in their area.

3. Relationship with existing institutions

The detailed interaction of the TVD as an auditor with the existing Divisions/Units within the FC is depicted in the cross-functional process maps in appendix 1-10. The existing Divisions and Units will continue to perform their mandated functions while the TVD remain at an arm's length as verifier. The TVD and TVC will report to the MLFM through the Forestry Commission.

4. Financing

GOG will seek external assistance in the establishment of the TVD to assist in technical design and to help meet investment costs of establishing the TVD and its core functions. In the long term the GOG expects that fees/rents levied on the timber sector will cover the costs of operating the TVD and the regulatory controls governing timber extraction.

The overall implementation budget of the TVD will cover the following areas:

- cost of procuring the tracking system;
- cost of sourcing technical assistance through the accredited verifier;

- logistics and "tooling up" for TVD set as well as requirements of other Divisions for implementing the LAS;
- cost of training of staff of the TVD as well as staff of the FC whose services are crucial to the implementation of the system;
- Initial cost of assistance to industry to enable basic technological readiness (IT) for the operation of the system.

5. Complaints procedure

Complaints on the operation of the TVD in the issuance of verification datasets (i.e. the confirmation of the end of the reconciliation and verification process allowing for issuance of FLEGT licences) will be received by the TVC. The purpose of the complaints procedure will be to provide an avenue for aggrieved parties to seek redress as well as to promote public confidence in the operation of the verification system. TVC will therefore appoint a team of adjudicators headed by a legal practitioner qualified to be a high court judge.

Appendix 1 - 10 – WTS Descriptive Charts

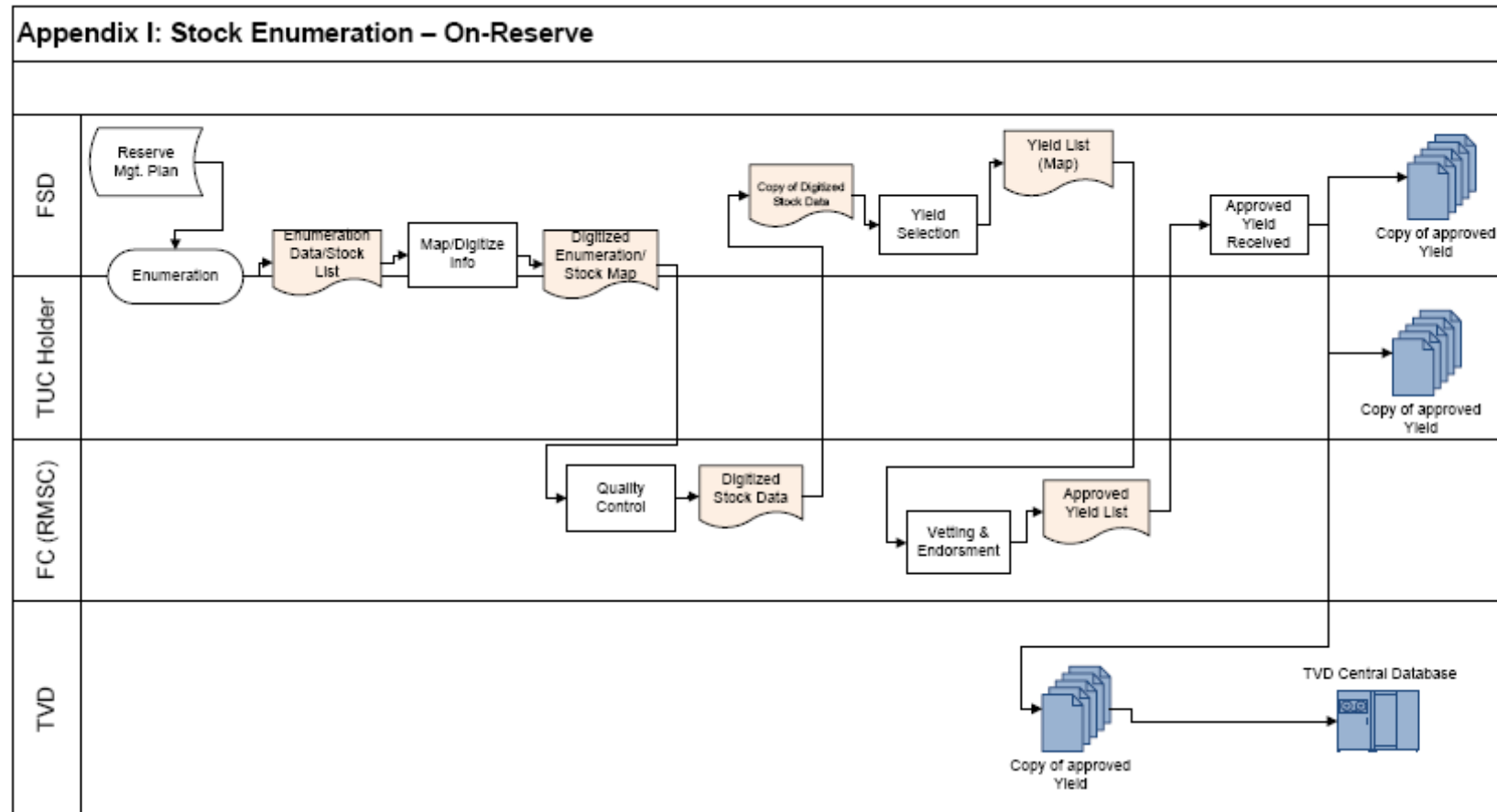

Appendix II: Tree Felling & Log Production

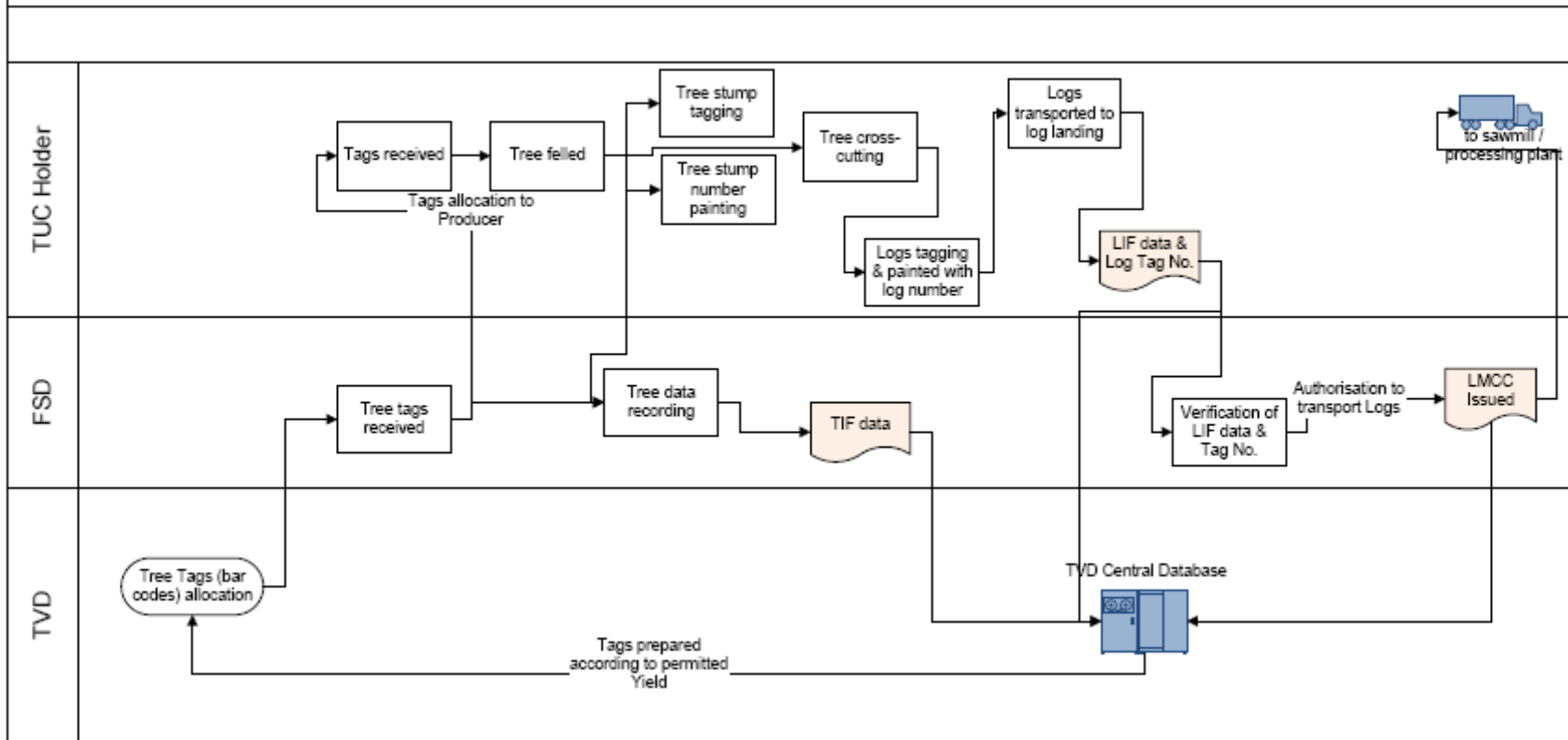

Appendix III: Post Harvest Audit

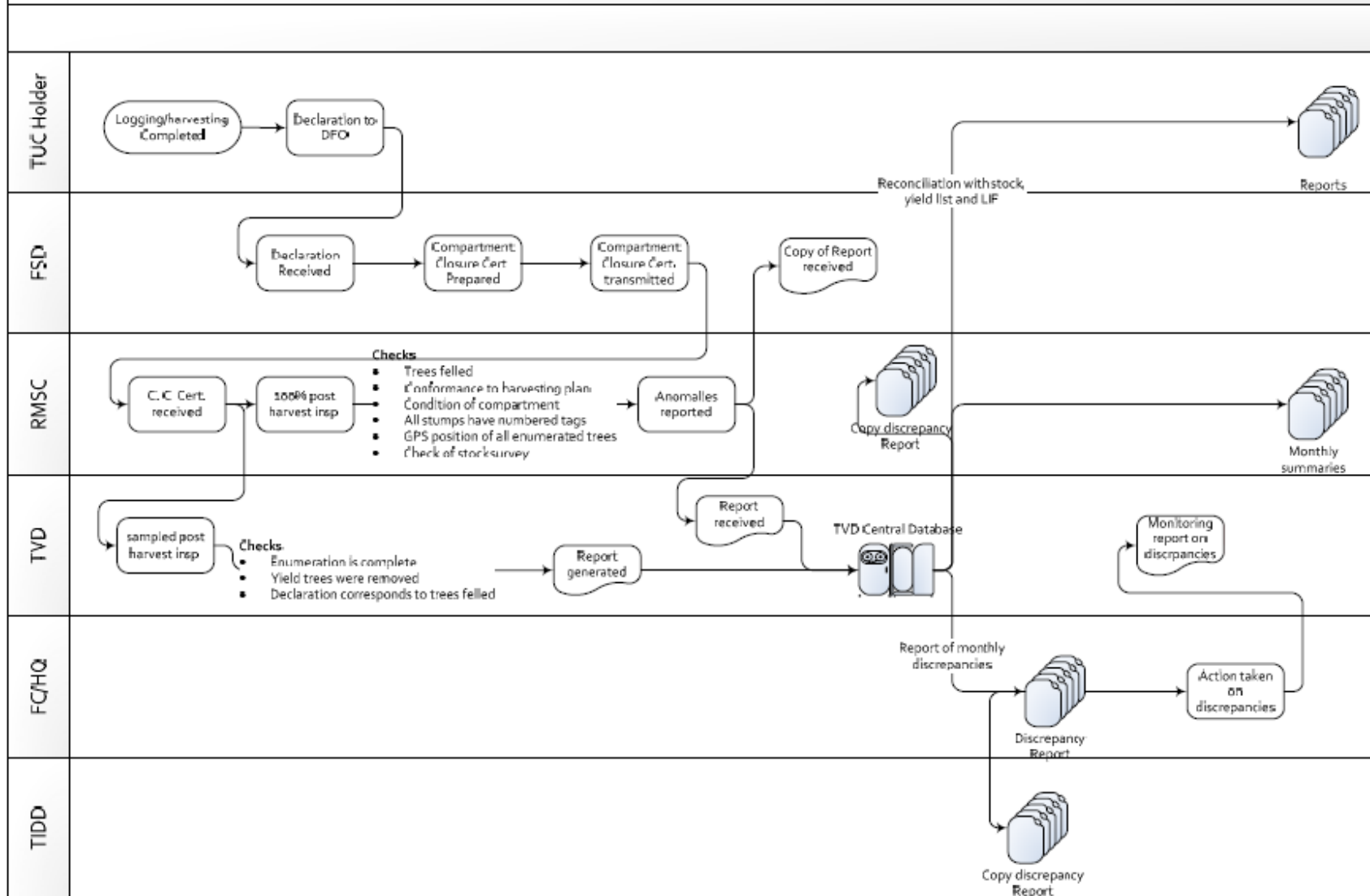

Appendix IV: Log Transport & Inspections

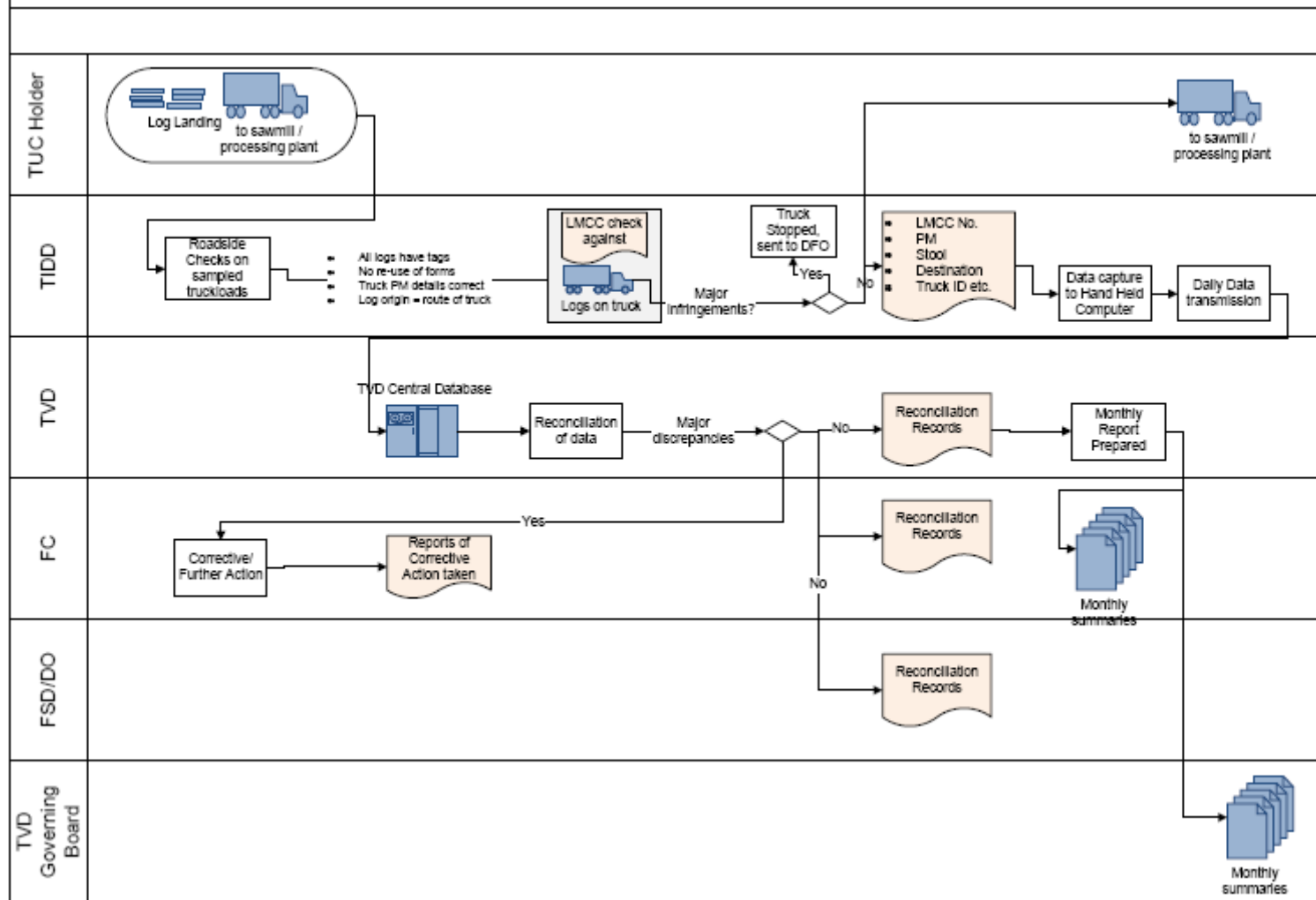

Appendix VI: Log Imports

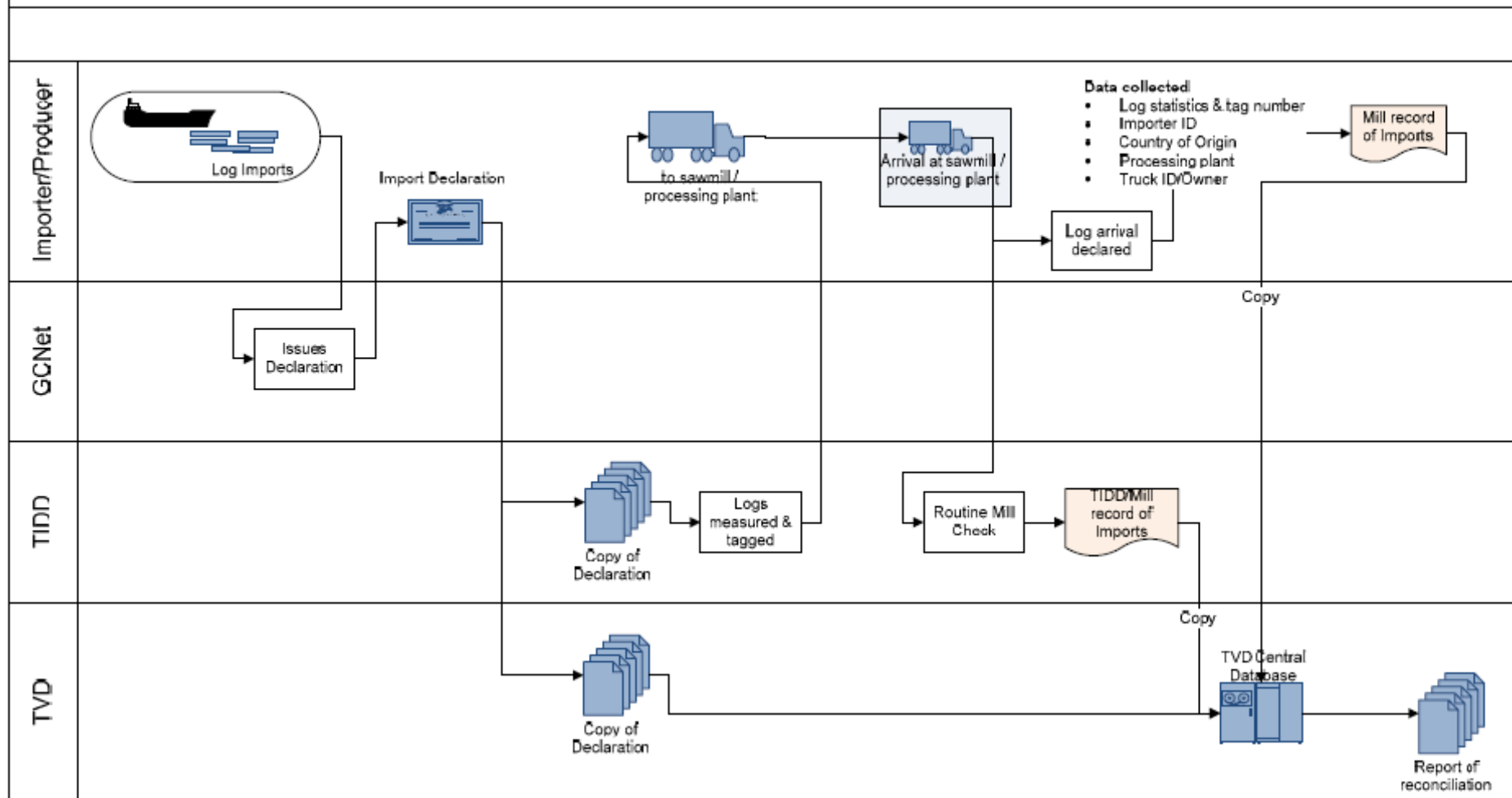

Appendix VII: Log Arrival at Processing Plant

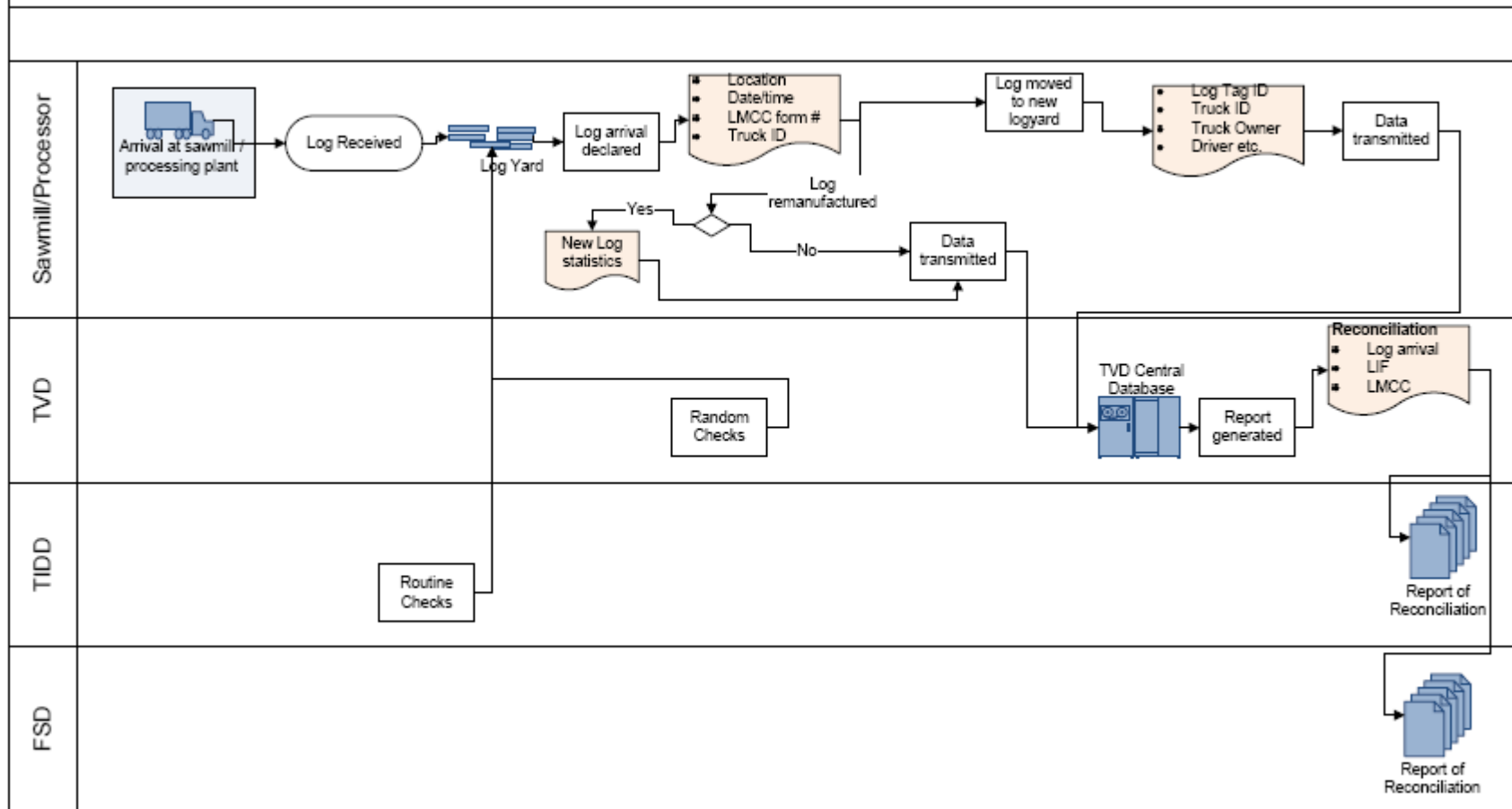

Appendix VIII: Log Processing

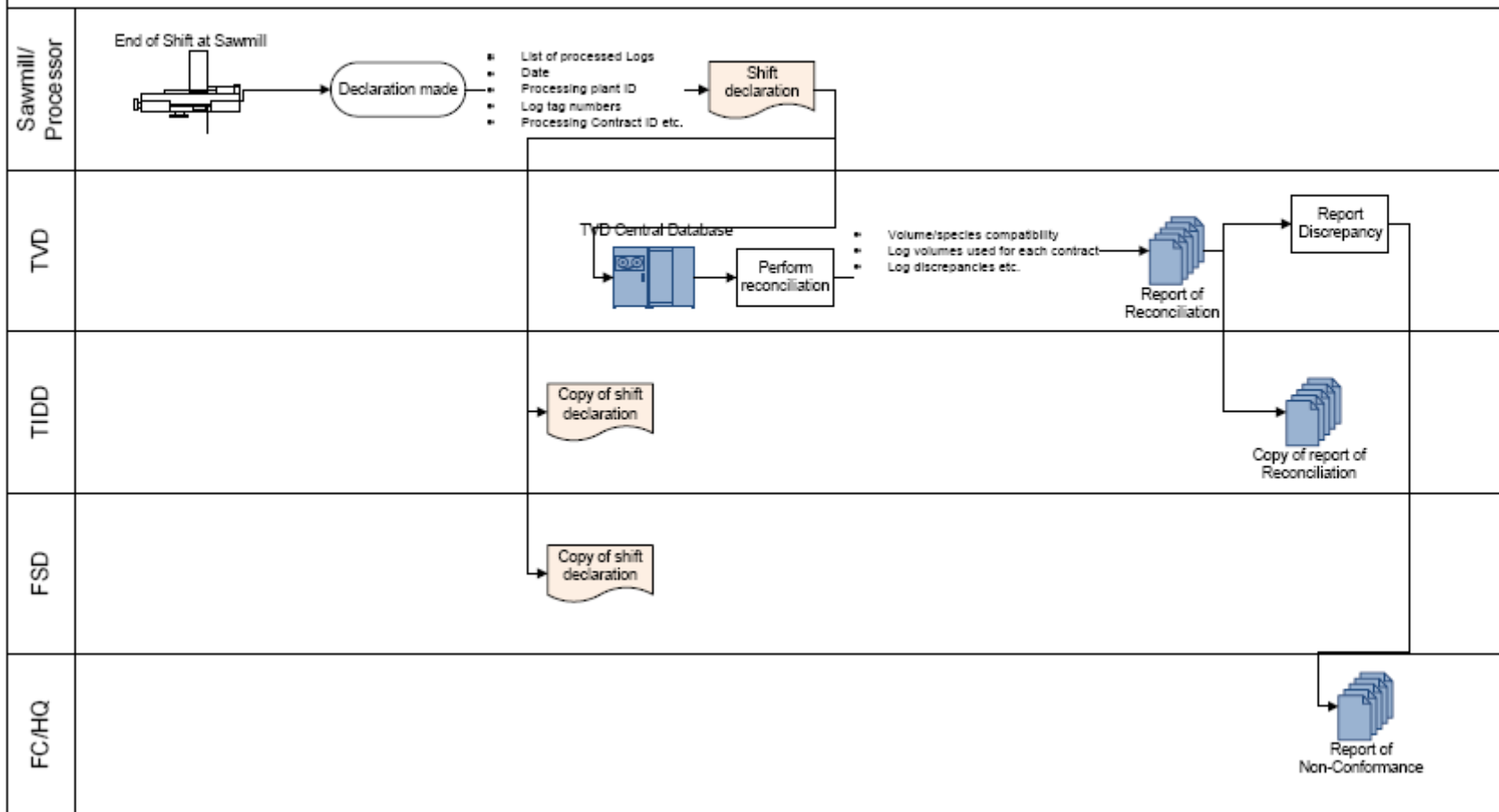

Appendix IX: Processed Wood

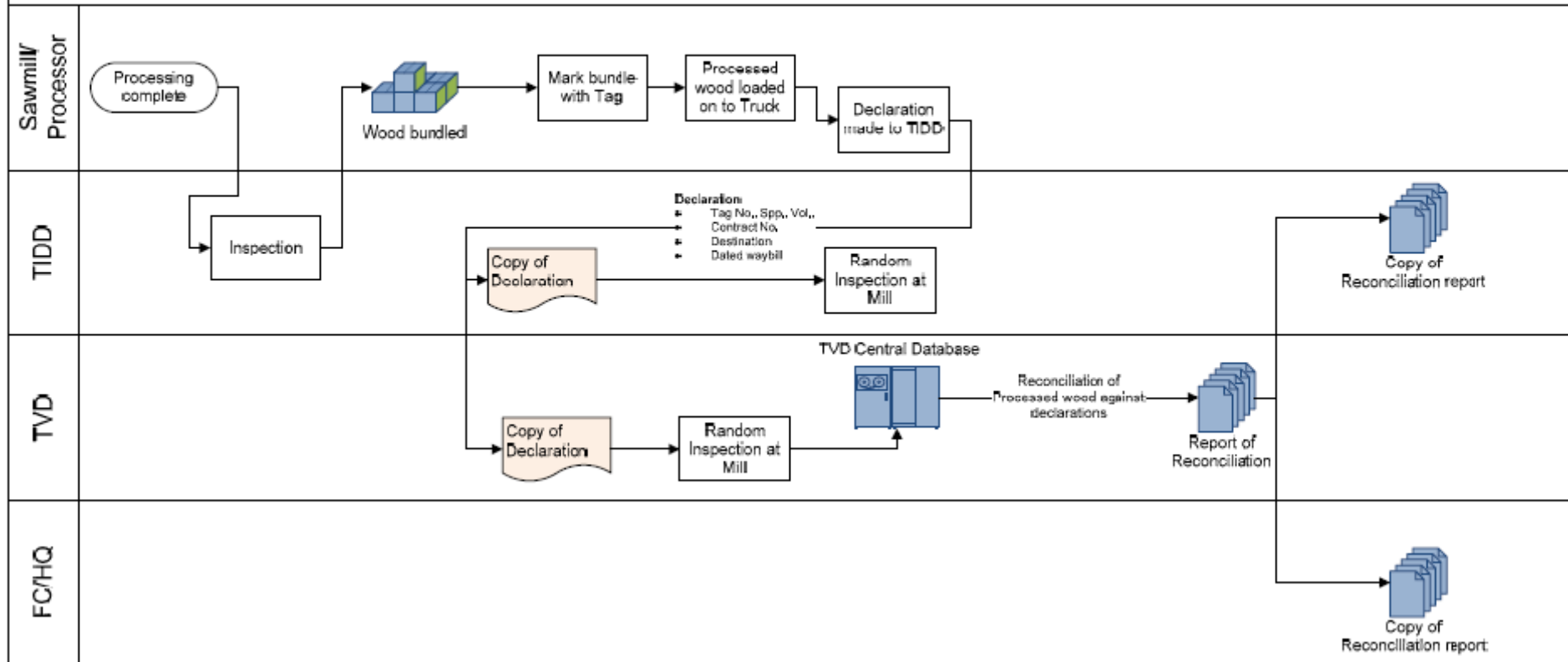

Appendix X: Export of Processed Wood Bundles

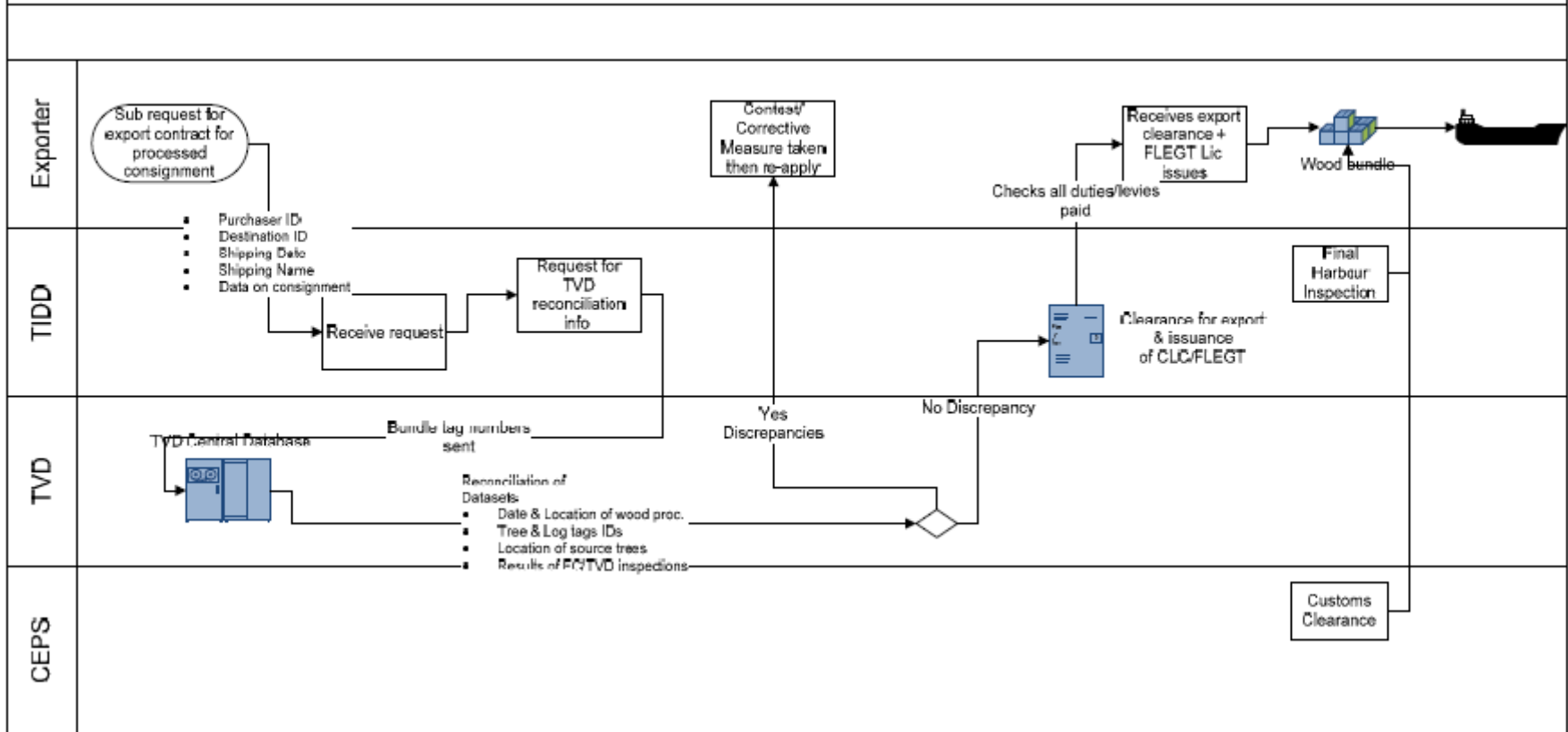

ACRONYMS

CEO	Chief Executive Officer
CEPS	Customs Excise and Preventive Services
CLC	Certificate of Legal Compliance
CoC	Chain of Custody
CoP	Certificate of Purchase
DCE	District Chief Executive
DfID	Department for International Development
DFO	District Forest Office
EU	European Union
FC	Forestry Commission
FLEGT	Forest Law Enforcement, Governance and Trade
FMP	Forest Management Plan
FMU	Forest Management Unit
Form CO2	
Form CO3	
FR	Forest Reserve
FSC	Forest Stewardship Council
FSD	Forest Service Division
GCNet	Ghana Community Network Services Ltd.
GFTN	Global Forest and Trade Network
GIS	Geographic Information System
GPS	Global Positioning System
GSBA	Globally Significant Biodiversity Area
HHC	Handheld Computer
HQ	Headquarters

ICT	Information and Communication Technology
ID	Identification/Identity (as used in Information Systems)
ILMCC	Import Log Measurement and Conveyance Certificate
IM	Independent Monitor
LAS	Legality Assurance System
LI	Legislative Instrument
LIC	Lumber Inspection Certificate
LIF	Log Information Form
LMCC	Log Measurement and Conveyance Certificate
LSE	Large Scale Enterprise
MoFEP	Ministry of Finance and Economic Planning
MLFM	Ministry of Lands, Forestry and Mines
NGO	Non-Governmental Organisation
NTFP	Non-Timber Forest Product
OASL	Office of Administrator of Stool Lands
OFR	Off Forest Reserve
PC	Personal Computer
PEFC	Programme for the Endorsement of Forest Certification
PLMCC	Plantation Log Measurement and Conveyance Certificate
PPC	Plantation Production Certificate
PW	Processed Wood
RFID	Radio Frequency Identification Device
RFO	Regional Forest Office
RMSC	Resource Management Support Centre
RS	Range Supervisor

SME	Small and Medium Scale Enterprise
SP	Salvage Permit
SRA	System Requirement Analysis
TIDD	Timber Industry Development Division
TIF	Tree Information Form
TO	Technical Officer
TREC	Timber Rights Evaluation Committee
TSP	Temporary Sample Plot
TUC	Timber Utilisation Contract
TUP	Timber Utilisation Permit
TVD	Timber Validation Department
VAT	Value Added Tax
VIC	Veneer Inspection Certificate
VLC	Verification of Legal Compliance
VLTP	Validation of Legal Timber Programme
VPA	Voluntary Partnership Agreement
WTS	Wood Tracking System

TERMS OF REFERENCE for INDEPENDENT MONITORING

Within the framework of implementing the Ghana- EU Partnership Agreement, Ghana shall appoint, in consultation with the EU, an Independent Monitor (IM) for the purpose of monitoring the implementation of relevant procedures and control measures in particular those related to the Legal Assurance Scheme (LAS). Independent monitoring aims to provide assurance to all interested parties, including the JMRM, that the LAS is functioning effectively and thereby ensure the credibility of licences issued under this Agreement.

1. Key tasks of the Independent Monitor:

The main tasks of the IM are as follows:

- Assess the implementation and effectiveness of the LAS;
- Conduct field investigations on the relevant work of the forest regulatory agencies at all levels of the forest, industry and supply chain including cross checks with information held by EU Competent Authorities;

- Identify and document systems failures and assess whether corrective actions have been recommended and taken by the regulatory agencies to address non-compliances and systems failures;
- Assess the effectiveness of corrective actions undertaken;
- Assess the adequacy of data management systems supporting the LAS and the issuance of FLEGT licences;
- Assess the completeness and accuracy of published FLEGT relevant production and trade statistics. Assess the effectiveness of licence verification procedures on entry to the EU;
- Report findings.

2. Methodology

The IM shall have publicly available documented procedures for carrying out monitoring, assessing monitoring observations and preparing reports:

- The monitoring procedures shall meet internationally accepted best practices such as those set out in ISO 17021 and ISO 19011 or equivalent;

- The IM shall prepare a monitoring schedule for the contract period including dates when draft reports will be delivered;
- The IM methodology shall be evidence-based;
- The audit will be carried out at approximately 6 month interval in the first year shifting to annual intervals;
- The documented procedures shall provide guidelines for sample checking of documents, records and operations which shall be agreed with the contracting authority;
- The documented procedures shall include provision for utilising information received from stakeholders that are not necessarily directly involved in implementing the LAS;
- All monitoring observations shall be documented;
- The monitoring shall determine that all aspects of the LAS are functioning as intended and in particular identify any systemic failures evidenced by non-compliances (*non-conformity?*) observed and assess the regulatory agencies requests for Corrective Actions and respective compliance with these;

- The monitoring reports shall contain all relevant information on the monitoring program and findings. An outline for the monitoring reports and summary reports shall be provided in the documented procedures;
- The Parties shall ensure that the IM has free access to relevant information unless it is classified as restricted, as well as personnel involved in the implementation of the LAS, their verification activities, relevant activities in the forest, along timber supply chains, at processing facilities and at timber export and import locations.

3. Qualifications

The IM shall be an impartial and independent organisation that has proven competence in auditing practices and the forest sector. Experience of the forest sector in Ghana or in other tropical timber producing countries would be an advantage:

- The IM shall not be directly involved in forest management, timber processing, trade in timber or control of the forest sector in Ghana or EU;
- Commercial service providers contracted by the Government of Ghana to provide other services in support of management and regulation of the forest sector are not eligible for selection;

- The IM shall have an internal quality system that meets the requirement of ISO 17021 or its equivalent;
- The IM and its employees nominated to undertake the monitoring tasks shall have proven track-records on the auditing of forest management, timber processing industry and related supply chain controls;
- If the IM is not a Ghanaian registered organisation, it will be required to engage such an organisation as a local partner; and
- to develop the capacity of that organisation to undertake IM over an agreed period to be specified in its contract.

4. IM Reporting

The IM reports will include: (i) a full report for consideration by the Parties containing all relevant information on the monitoring programme and effective functioning of the LAS and FLEGT licences; and (ii) a public summary report based on the full report and summarising key findings and systems failures identified.

The IM will report in the first instance to the contracting authority (Ministry of Lands, Forests and Mines and after 30 days for the contracting authority to comment on the accuracy, copies of a report will then be sent to both Parties through the JMRRM.

The IM will be required to provide information should further clarification be required by the JMRRM.

The IM will prepare final reports that take into account and report on any clarifications provided by either Party on the draft reports.

5. Institutional arrangements

Ghana will contract the IM in consultation with the EU on the basis of documented and transparent selection procedures.

The IM's reports and any necessary corrective actions will be discussed by the Joint Monitoring and Review Mechanism.

The JMRRM will prepare and publish public summary reports of the IMs findings.

The IM will report to the GoG, which will be responsible for:

- Reviewing draft reports and providing any necessary commentary to ensure their accuracy and clarity and requesting through the JMRRM that the EU reviews draft reports and provides any necessary commentary;
 - deciding on actions to be taken on the basis of the findings of monitoring reports, in particular those necessary to address systemic problems in the LAS and problems in the implementation of corrective actions requested by the various regulatory agencies;
 - informing the IM and interested stakeholders on any corrective actions initiated on the basis of monitoring reports.
-

CRITERIA TO ASSESS THE OPERATIONAL LEGALITY ASSURANCE SYSTEM
OF GHANA

The FLEGT EU- Ghana Partnership Agreement (FLEGT-PA) provides for the development and implementation of a Legality Assurance System (LAS) to ensure that all timber products specified in the agreement and exported from Ghana to the EU have been legally produced. The LAS should include: a definition of legally-produced timber that describes the laws that must be complied with in order for a licence to be issued; Supply chain controls to track timber from forest operations to the point of exports; Verification procedures to ensure and document compliance with all elements of the legality definition and control of the supply chain; Licensing procedures and issuance of FLEGT licences; and Independent monitoring to provide assurance that the system is working as planned.

The Community expectations with regard to the LAS are outlined in a series of briefing notes prepared by an expert group convened by the European Commission (EC)¹.

¹ http://ec.europa.eu/development/policies/9interventionareas/environment/forest/flegt_briefing_notes_en.cfm.

Assessment Criteria

The LAS will be subject to an independent technical evaluation before the licensing scheme becomes fully operational, the Terms of Reference for which will be jointly agreed between the Parties, the Joint Monitoring and Review Mechanism. These assessment criteria describe what the LAS system is expected to produce and will provide the basis for the Terms of Reference for the evaluation. The evaluation will aim to:

- (i) review the system description with special focus on any revisions made after the FLEGT-PA was signed and
- (ii) examine the functioning of the system in practice.

Section 1: Legality definition

Legally-produced timber needs to be defined on the basis of the existing laws of Ghana. The definition used must be unambiguous, objectively verifiable and operationally workable and, as a minimum, include those laws which cover:

Harvesting rights: Granting of legal rights to harvest the timber within legally gazetted boundaries.

Forest operations: Compliance with legal requirements regarding forest management including compliance with relevant environmental and labour legislation.

Fees and taxes: Compliance with legal requirements concerning taxes, importation, royalties and fees directly related to timber harvesting and harvest rights.

Other users: Respect for other parties' legal tenure or use rights to land and other resources that may be affected by timber harvest rights, where such other rights exist.

Trade and customs: Compliance with legal requirements for trade and customs procedures.

Is it clear what legal instrument underpins each element of the definition?

Are criteria and indicators that can be used to test compliance with each element of the definition specified?

Are the criteria/ indicators clear, objective and operationally workable?

Do the indicators and criteria clearly identify roles and responsibilities of different actors and does verification assess performance of all relevant actors?

Does the legality definition include the main areas of existing law outlined above, if not; why were certain areas of law left out of the definition?

Through the stakeholder engagement in developing the definition were all the main areas of applicable law considered?

Does the legality verification system incorporate the main legal provisions identified through stakeholder discussion?

Has the legality definition and enforcement matrix been amended since the FLEGT-PA concluded?
Have indicators and criteria been developed to ensure verification of these changes?

Section 2: Control of the Supply Chain

Systems to control the supply chain must provide credible assurance that timber products can be traced through the supply chain from the point of harvesting or legal import to the point of export. It will not always be necessary to maintain physical traceability for a log, log load or timber product from the point of export back to the forest of origin, but it is always needed between the forest and the first point of mixing (e.g. a timber terminal or a processing facility).

2.1. Use rights: There is clear delineation of areas where forest resource rights have been allocated and identification of the holders of those rights.

Does the control system ensure that only timber originating from a forest area with valid and permissible use rights enters the supply chain?

Does the control system ensure that enterprises carrying out harvesting operations have been issued appropriate use rights for the forest areas concerned?

Are the procedures for issuing use rights and the information on issued use rights and their holders available in public domain?

2.2. Systems to control the supply chain: There are effective mechanisms for tracing timber through the supply chain from the point of harvesting to the point of export.

The approach for identifying material may vary and is likely to range from the use of labels for individual items to the reliance on documentation accompanying a load or batch. The selected method should reflect the type and value of material and the risk of contamination with illegal or unverified material.

Are all the supply chain alternatives identified and described in the control system?

Are all stages in the supply chain identified and described in the control system?

Are methods defined and documented to (a) identify the product origin and (b) prevent mixing with material from unknown sources in the following stages of the supply chain?

- timber in the forest
- transport
- interim storage
- arrival at primary processing facilities
- processing facilities
- interim storage
- transport
- arrival at point of export

Which organisations are in charge of controlling the timber flows? Do they have adequate human and other resources for carrying out the control activities?

2.3. Quantities: There are robust and effective mechanisms for measuring and recording the quantities of timber or timber products at each stage of the supply chain, including reliable pre-harvest estimates at appropriate accuracy of the volume of standing timber in each harvesting site.

Does the control system produce quantitative data of inputs and outputs at the following stages of the supply chain?

- standing timber
- logs in the forest
- transported and stored timber
- timber arriving at the primary processing plant
- within the processing facilities
- material arriving at export point

Which organisations are responsible for feeding the quantitative data into the control system? How is the quality of data controlled?

2.4. Reconciliation: All data are recorded in a way which makes it possible to reconcile them with the prior and subsequent links in the chain in a timely manner. Reliable reconciliation is carried out for the entire supply chain.

Is all quantitative data recorded in a way which makes it possible to reconcile quantities with the prior and subsequent stages in the supply chain in a timely manner?

Are methods developed to assess coherence between inputs of raw materials and outputs of processed products at sawmills and other plants?

Is reliable reconciliation by individual items or batches of timber products possible throughout the entire supply chain?

What information systems and technologies are applied for storing and reconciliation of the data and for reporting? Are there robust systems in place for securing the data?

Which organisation is responsible for the data reconciliation? Does it have adequate human and other resources for carrying out the data management activities?

What information on the supply chain control is made publicly available? How can the interested parties have access to this information?

2.5. Mixing of legally verified timber with other approved timber: If mixing of logs or timber from verified legal sources with logs or timber from other sources is allowed, there are sufficient controls in place to exclude material from unknown sources or which was harvested without legal harvesting rights.

Does the control system allow mixing of verified timber with other approved timber (e.g. with imported timber or timber originating from a forest area with clear legal harvesting rights but still not covered by the full verification process)?

What control measures are applied for these cases? For example, do controls ensure that verified output claimed does not exceed verified input at each stage?

2.6. Imported timber products: There are adequate controls to ensure that imported timber products have been legally imported

How is the legal import of timber and timber products demonstrated?

What evidence is required to demonstrate that imported products originate from trees harvested legally in a third country?

Does the LAS identify imported timber and timber products throughout the supply chain?

Where imported timber is used, can the country of original harvest be identified on the FLEGT licence, including that of components in composite products?

Section 3: Verification

Verification provides adequate checks and control to ensure the legality of timber. Verification must be sufficiently robust and effective to ensure that any non-compliance with requirements, either in the forest or within the supply chain is identified and action is taken in a timely manner to resolve them.

3.1. Organisation: Verification is carried out by a government, or third-party organisation, or some combination of these, which has adequate resources, management systems and skilled and trained personnel, as well as robust and effective mechanisms to control conflicts of interest.

Has the government appointed a body/bodies to undertake the verification tasks? Is the mandate (and associated responsibilities) clear and in the public domain?

Has the verification body adequate resources for carrying out the verification of the legality definition and the systems for controlling the timber supply chain?

Does the verification body have a documented management system that:

- Ensures adequate competence/experience for the personnel of the verification body?
- Applies internal control/supervision?
- Includes mechanisms to control conflicts of interest?
- Ensures transparency of the system?
- Defines and applies verification methodology?

3.2. Verification against the legality definition: There is a clear definition setting out what has to be verified. The verification methodology is documented and ensures that the process is systematic, transparent, evidence-based, carried out at regular intervals and covers everything included within the definition.

Does the verification methodology cover all elements of the legality definition and include tests of compliance with all specified indicators?

Does verification require?

- checks of documentation operating records and field operations (also unannounced);
- collection of information from external interested parties;
- maintenance of verification records that allows checking by internal auditors and the IM.

Are institutional roles and responsibilities clearly defined and applied?

Are the verification results against the legality definition made publicly available? How can the interested parties get access to this information?

3.3. **Verification of systems to control the supply chain:** there is a clear scope setting out what has to be verified which covers the entire supply chain from harvesting to export. The verification methodology is documented and ensures that the process is systematic, evidence-based, carried out at regular intervals, and covers everything included within the scope, and includes regular and timely reconciliation of data between each stage in the chain.

Does the verification methodology fully cover checks on supply chain controls? Is this clearly spelt out in verification methodology?

What evidence is there to demonstrate application of verification of supply chain controls?

Are institutional roles and responsibilities clearly defined and applied?

Are the verification results on the supply chain control made publicly available? How can the interested parties get access to this information?

3.4. Non-compliances: There is an effective and functioning mechanism for requiring and enforcing appropriate corrective action where non-compliances are identified?

Does the verification system define the above requirement?

Are mechanisms developed for handling non-compliances are they applied in practice?

Are there adequate records available on the non-compliances identified and corrective actions taken? Is the effectiveness of corrective actions evaluated?

What information on identified non-compliances goes into the public domain?

Section 4: Licensing

Ghana has assigned a Licensing Authority with overall responsibility for issuing FLEGT licences. The FLEGT licences are issued on the basis of either individual shipments or approved market participants.

4.1. Organisation:

What body is assigned responsibility to issue FLEGT licences?

Are the roles of the licensing authority and its personnel with regard to issuance of FLEGT licences clearly defined and publicly available?

Are the competence requirements defined and internal controls established for the personnel of the licensing authority?

Has the licensing body adequate resource for carrying out its tasks?

4.2. Issuance of licences:

Does the licensing body have documented procedures for issuing the licences? Are these publicly available including any fees payable?

What evidence is there that these procedures are properly applied in practice?

Are there adequate records available on the issued and rejected licences? Do the records clearly demonstrate the evidence based on which the licences are issued?

4.3. Consignment-based licences

Is the licensing based on individual shipment (consignments)?

Is the legality of an export consignment demonstrated through verification and traceability systems of the government?

Are the requirements for issuing licences clearly specified and available to exporter?

What information on issued licences goes into the public domain?

Section 5: Principles on independent monitoring procedures

Independent Monitoring (IM) is a function that is independent of Ghana's forest sector regulatory bodies. It aims to provide credibility to the FLEGT licensing scheme by checking that all aspects of Ghana's LAS are operating as intended.

5.1. Institutional arrangements

5.1.1. Designation of authority: Ghana has formally authorised the independent monitoring function and it operates in an effective and transparent way

5.1.2. Independence from other elements of the LAS: There is a clear separation between organisations and individuals that are involved in management or regulation of the forest resource and those involved in Independent Monitoring.

Has the government documented independence requirements for the third-party monitor (TPM)? Is it required that the organisations or individuals with a commercial interest or an institutional role in the Ghanaian forest sector are not eligible to perform the third-party monitoring function?

5.1.3. Appointment of the Third-Party Monitor: The TPM was appointed through a transparent mechanism and there are clear and publicly-available rules regarding its operations

Has the government made the terms of reference for the TPM publicly available?

Has the government documented the procedures for appointing the TPM and made them publicly available?

5.1.4. Establishment of a complaints mechanism: There is a mechanism for handling complaints and disputes that arise from independent monitoring. This mechanism is adequate to deal with any complaints about the operation of the licensing scheme.

Is there a documented complaints mechanism in place that is available to all interested parties?

Is it clear how complaints are received, documented, escalated (where necessary) and responded to?

5.2. Third-Party Monitor

5.2.1. Organisational and technical requirements: TPM is independent of other components of the Legality Assurance System and operates in accordance with a documented management structure, policies and procedures that meet internationally-accepted best practice.

Does the TPM operate in accordance with a documented management system that meets the requirements of ISO Guide 62, 65, or similar standards?

5.2.2. Monitoring methodology: The TPM's methodology is evidence-based and carried out at minimum specified intervals

Does the TPM's methodology specify basing all findings on objective evidence concerning functioning of the LAS?

Does the TPM's methodology specify the maximum intervals at which each element of the TLAS will be checked?

5.2.3. Scope of monitoring: The TPM operates according to terms of reference that clearly specify what has to be monitored and which cover all agreed requirements for the issuance of FLEGT licences.

Does the TPM's methodology cover all elements of the LAS and specify the main tests of effectiveness?

5.2.4. Reporting requirements: The TPM reports regularly to the Joint Monitoring and Review Mechanism on the integrity of the legality assurance scheme, including non-compliances, as well as its assessment of corrective actions taken to address them?

Do the TPM's terms of reference specify the reporting requirements and reporting intervals?

SCHEDULE FOR THE IMPLEMENTATION OF THE AGREEMENT

No.	Milestones	Year 1			Year 2			Year 3						
		Q1	Q2	Q3	Q4	Q5	Q6	Q7	Q8	Q9	Q10	Q11	Q12	
1	Capacity building													
2	VPA Awareness campaign													
3	WTS Provider Selected													
4	Subsidiary Legislation Introduced													
5	TVD Established													
6	Piloting of LAS begins													
7	LAS Pilot Reviewed													
8	LAS Implemented Nationwide													
9	FLEGT Products Promotion begins													
10	FLEGT licensed products exported													
11	EU ready to import FLEGT products													
12	Independent Monitor appointed													
13	Procurement Policies Introduced													
14	Promotion of verified legal on Domestic Market													
15	Forestry laws reviewed and consolidated													Month 48

¹ Year 1 starts when the Agreement is signed

SUPPORTING MEASURES FOR VPA IMPLEMENTATION

Industry restructuring and expansion of plantations will play major roles in achieving Ghana's vision of a sustainable forest sector. Industry restructuring will require capacity building of trade associations and the wood industry training centre, recapitalisation and retooling of the wood processing industry to support downstream processing. Plantation development, which in addition to expanding domestic wood supply will create opportunities for CDM related activities, will require land reforms, development of benefit sharing arrangement and significant levels of investment.

Implementation of the VPA, which will create the enabling environment for these investments, will require supporting measures for the development of a Legality Assurance Scheme, legal reforms, trade promotion and associated capacity building as well as measures focused on the domestic market. The supporting measures required for implementation of the VPA are summarised below.

1. Development of the LAS
 - 1.1. Capacity Building of
 - 1.1.1. Forest Services Division
 - 1.1.2. Timber Industry Development Division
 - 1.1.3. Forest Resource Management Centre
 - 1.1.4. ICT infrastructure to support timber industry link to WTS
 - 1.2. Independent monitoring
 - 1.3. TVD/TVC establishment
 - 1.4. MLFM (JMRF)

2. Other Capacity Building Requirements
 - 2.1. Other VPA related agencies (CEPS, Attorney General's, MoFEP)
 - 2.2. Civil Society
 - 2.3. Trade Associations

3. Legal Reforms
 - 3.1. Introduction of subsidiary legislation
 - 3.2. Review and consolidation of forestry laws

4. Trade Promotion
 - 4.1. Promotion of FLEGT licences
 - 4.2. Promotion of verified legal products
 - 4.3. Promotion of Procurement Policy in Ghana

5. Domestic Market
 - 5.1 Promotion of regulation of domestic market
 - 5.2. Promotion of alternative livelihoods
 - 5.3 Development of rubber wood and bamboo processing
 - 5.4. Promotion of Processing and utilisation of LUS
-

